

LISTA COMPONENTI
LIST OF COMPONENTS
LISTE DE COMPOSANTS
ERSATZTEILLISTE
LISTA DE LOS COMPONENTES

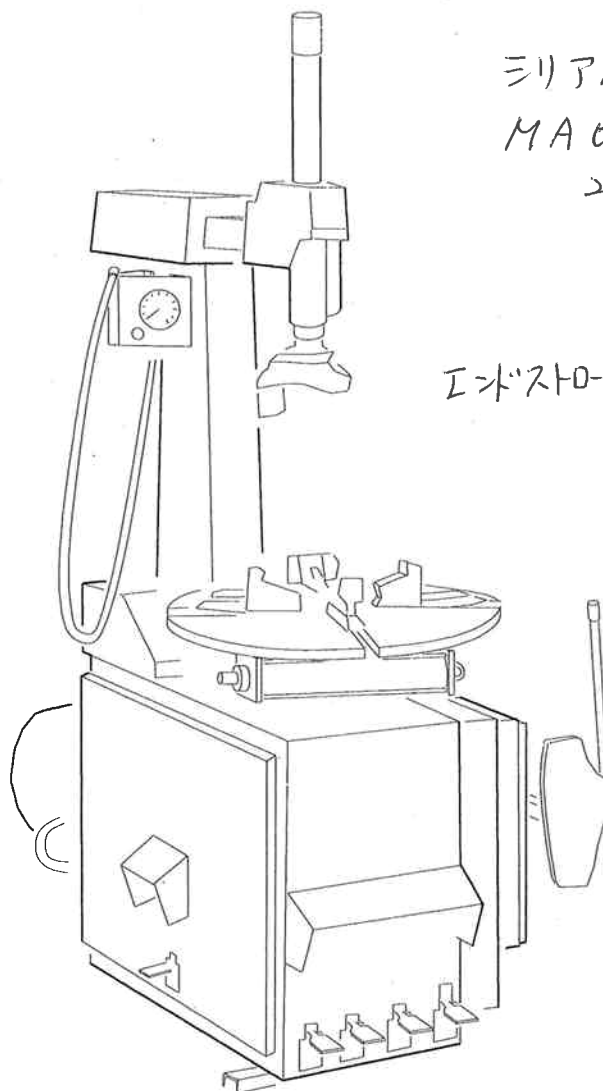

シリアル NO
MA010176
2004. 2月 入荷

変更点 (H21)
インストーブ(ビッドブリーカー スーパー)
タンク部 エキゾストバルブ

AS 942
AS 942 TI

I**ISTRUZIONI PER LA RICHIESTA DEI RICAMBI**

- 1) Consultando le tavole di seguito riportate, individuare esattamente il n. del particolare desiderato (Ex. Tav. A n. A10).
- 2) Dalla tabella ricambi, trovare il corrispondente codice (Ex. 36019156)
- 3) Nella richiesta specificare esattamente :
Il modello ed il n. di matricola della macchina.
Il codice ricambio (n. 8 cifre) del particolare desiderato.
Ex. AS 942 matr. 100, cod. 36019156.

GB**INSTRUCTIONS FOR REQUESTING SPARE PARTS**

- 1) Consulting the following tables, single out the exact n. of spare parts requested (Eg. Table A n. A10).
- 2) Find the corresponding spare parts code from the spare parts table (E. 36019156)
- 3) In the request specify exactly:
The model and serial n. of the machine.
The spare parts code (8 figures) of the requested spare part.
Eg. AS 942 serial n. 100, code 36019156.

F**INSTRUCTIONS POUR LA DEMANDE DE PIECES DE RECHANGE**

- 1) En consultant les tables ci-après, individualiser exactement le n. du détail désiré (Ex. Table A n. A10).
- 2) De la table des pièces de rechange, trouver le code correspondant (Ex. 36019156)
- 3) Dans la demande spécifier exactement :
Le modèle et le n. de matricule de la machine.
Le code pièce de rechange (n. 8 chiffres) du détail désiré.
Ex. AS 942 matr. 100, code 36019156.

D**ANWEISÜNG FÜR DIE ERSATZTEILANFORDERUNG**

- 1) Bestimmen Sie genau anhand der nach stehend angeführten Übersichtstafeln die Nummer des gewünschten Teils (z.B. Tav. A Nr. A10).
- 2) Aus der Ersatzteiltafel den entsprechen den Code aufnoieren Z.B. 36019156.
- 3) Bezeichnen Sie in der Anforderung klar und präzise:
Das Model und die Maschinennummer.
Den Ersatzteilcode (8 Ziffern) des gewünschten Teils.
Z.B. AS 942 matr. 100, cod. 36019156.

E**INSTRUCCIONES PARA EL PEDIDO DE REPUESTOS**

- 1) Consultando las tablas detalladas a continuación, identificar exactamente el n° de las piezas que se desean pedir (Ej. Tav. A n. A10).
- 2) Partiendo de la tabla, encontrar el código correspondiente (ej.: 36019156)
- 3) En el pedido especificar exactamente:
El modelo y el n° de la matricola de la máquina.
El código del repuesto (n° 8 cifras) de la pieza deseada.
Ej. AS 942 matr. 100, cod 36019156.

IMPORTANTE: per la richiesta dei ricambi far riferimento al codice ricambi (vedi pag. 14).
IMPORTANT: for the request of spare parts please refer to spare parts code (see page 14).
IMPORTANT: pour la demande de pièces de rechange faire référence au code des pièces de rechange (voir pages 14).
WICHTIG: für die Anforderung von Ersatzteilen die Ersatzteilcodes (siehe Seite 14) angeben.
IMPORTANTE: para pedir los repuestos remitirse al código repuestos (ver pag. 14).

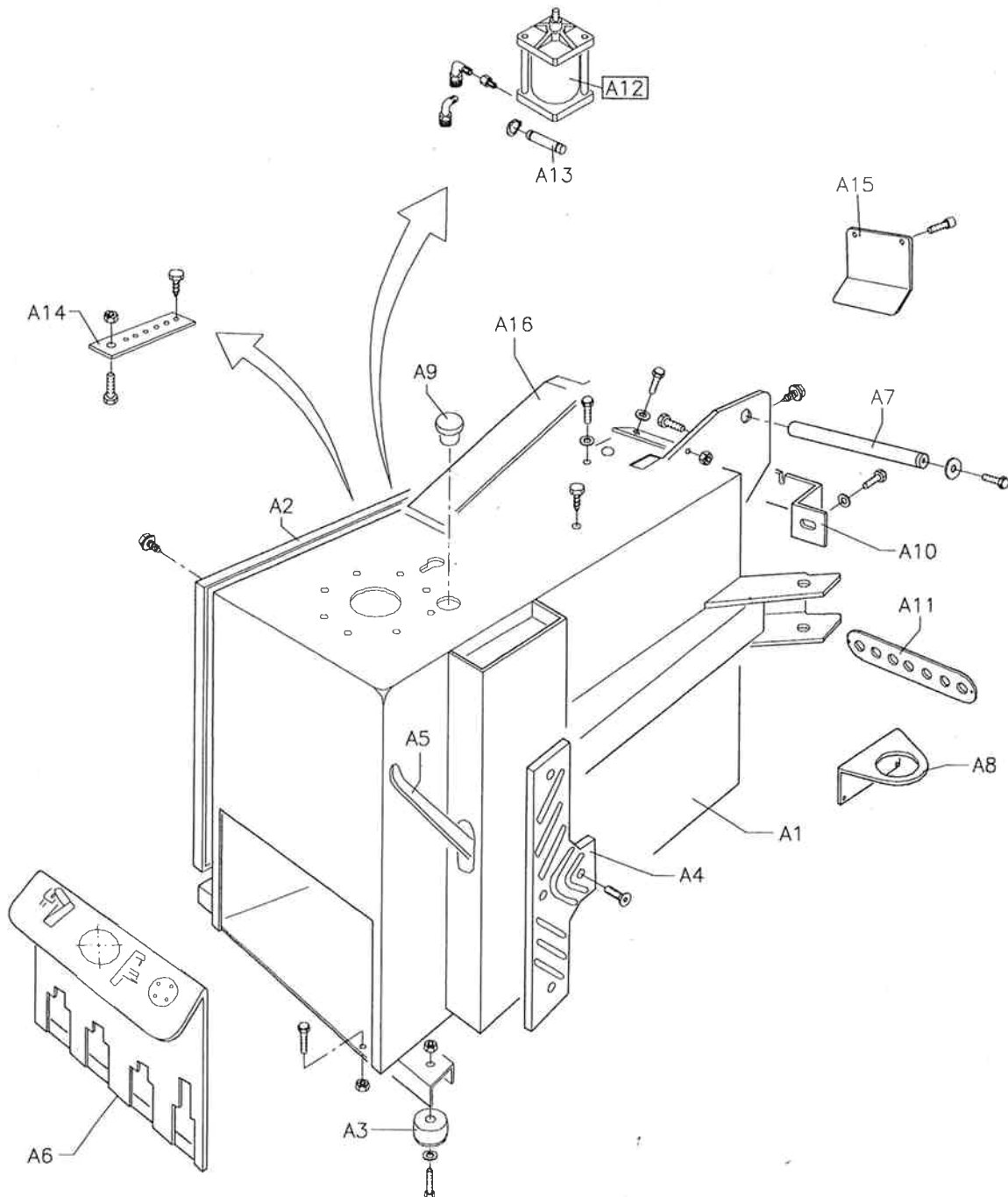



PIANTONE, ALBERO ORIZZONTALE, ALBERO VERTICALE
COLUMN, HORIZONTAL SHAFT, VERTICAL SHAFT
MONTANT, ARBRE HORIZONTAL, ARBRE VERTICAL
SÄULE, HORIZONTALE WELLE, VERTIKALE WELLE
PLANCHA, ARBOL HORIZONTAL, ARBOL VERTICAL

AS 942
AS 942 TI
TAV. B

IMPORTANTE: per la richiesta dei ricambi far riferimento al codice ricambi (vedi pag. 14).
IMPORTANT: for the request of spare parts please refer to spare parts code (see page 14).
IMPORTANT: pour la demande de pièces de rechange faire référence au code des pièces de rechange (voir pages 14).
WICHTIG: für die Anforderung von Ersatzteilen die Ersatzteilcodes (siehe Seite 14) angeben.
IMPORTANTE: para pedir los repuestos remitirse al código repuestos (ver pag. 14).

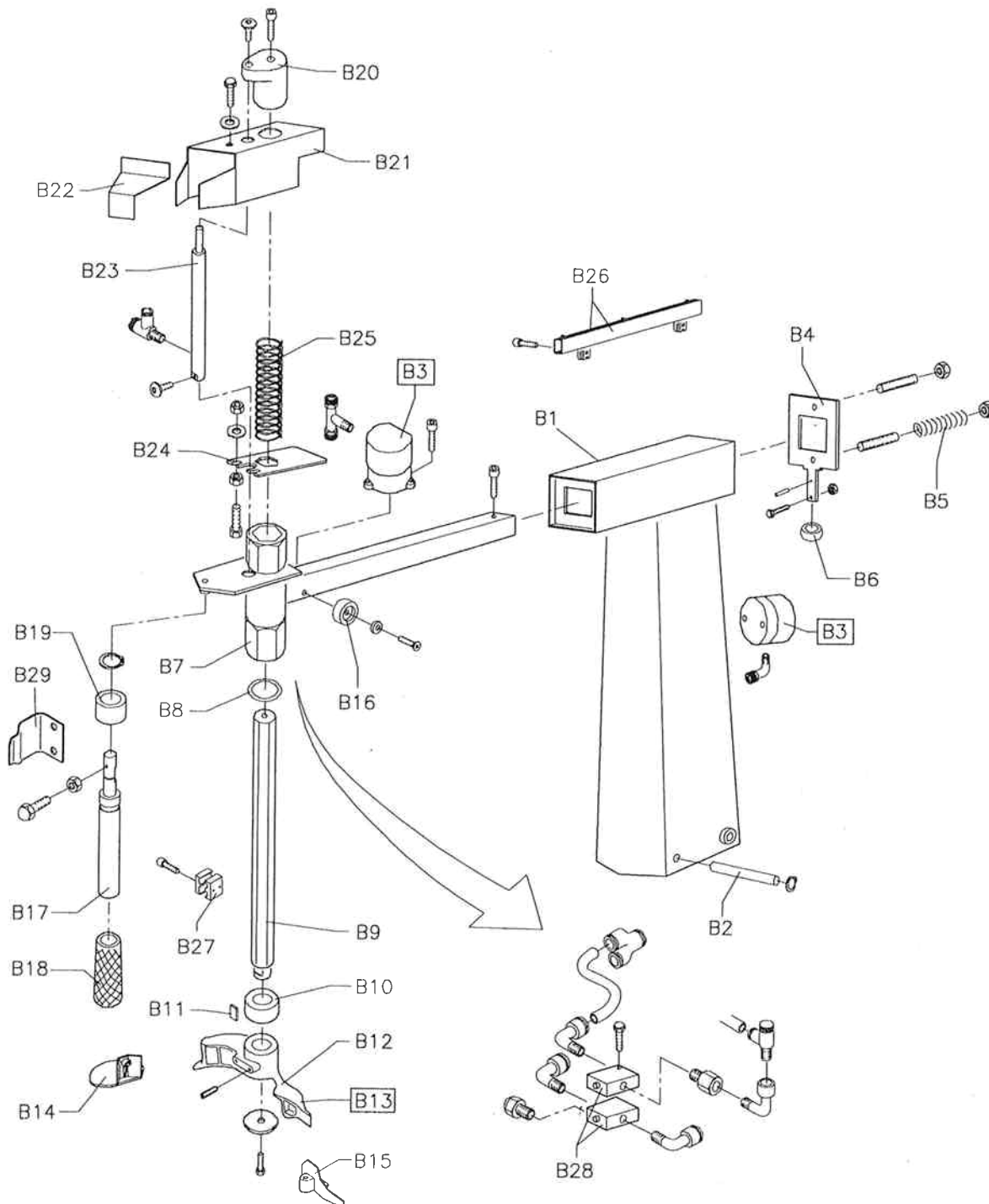

IMPORTANTE: per la richiesta dei ricambi far riferimento al codice ricambi (vedi pag. 15).
IMPORTANT: for the request of spare parts please refer to spare parts code (see page 15).
IMPORTANT: pour la demande de pièces de rechange faire référence au code des pièces de rechange (voir pages 15).
WICHTIG: für die Anforderung von Ersatzteilen die Ersatzteilcodes (siehe Seite 15) angeben.
IMPORTANTE: para pedir los repuestos remitirse al código repuestos (ver pag. 15).

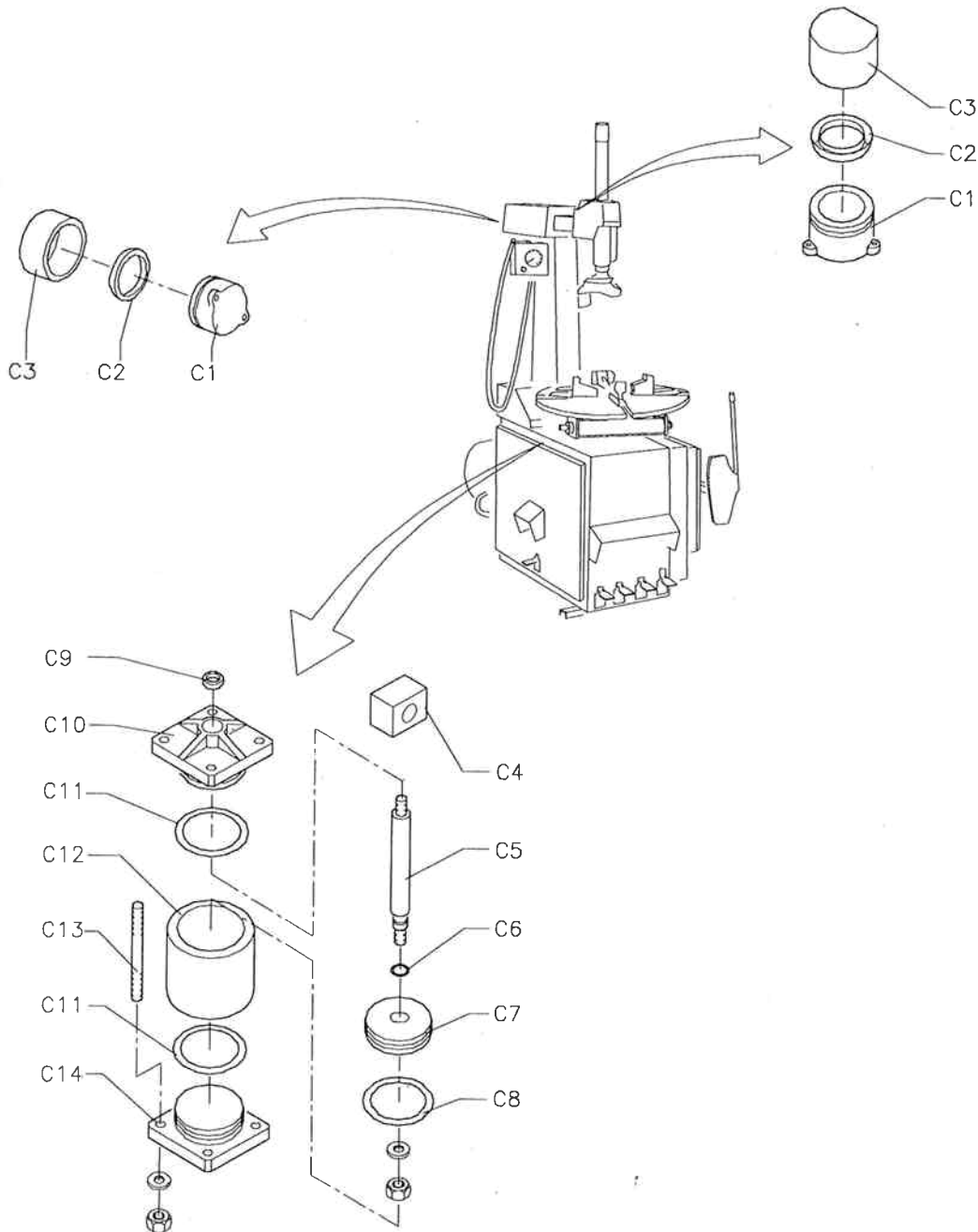



GRUPPO PEDALIERA
PEDAL UNIT
GROUPE PEDALES
PEDALEINHEIT
GRUPO PEDALES

AS 942
AS 942 TI
TAV. D

IMPORTANTE: per la richiesta dei ricambi far riferimento al codice ricambi (vedi pag. 16).
IMPORTANT: for the request of spare parts please refer to spare parts code (see page 16).
IMPORTANT: pour la demande de pièces de rechange faire référence au code des pièces de rechange (voir pages 16).
WICHTIG: für die Anforderung von Ersatzteilen die Ersatzteilcodes (siehe Seite 16) angeben.
IMPORTANTE: para pedir los repuestos remitirse al código repuestos (ver pag. 16).

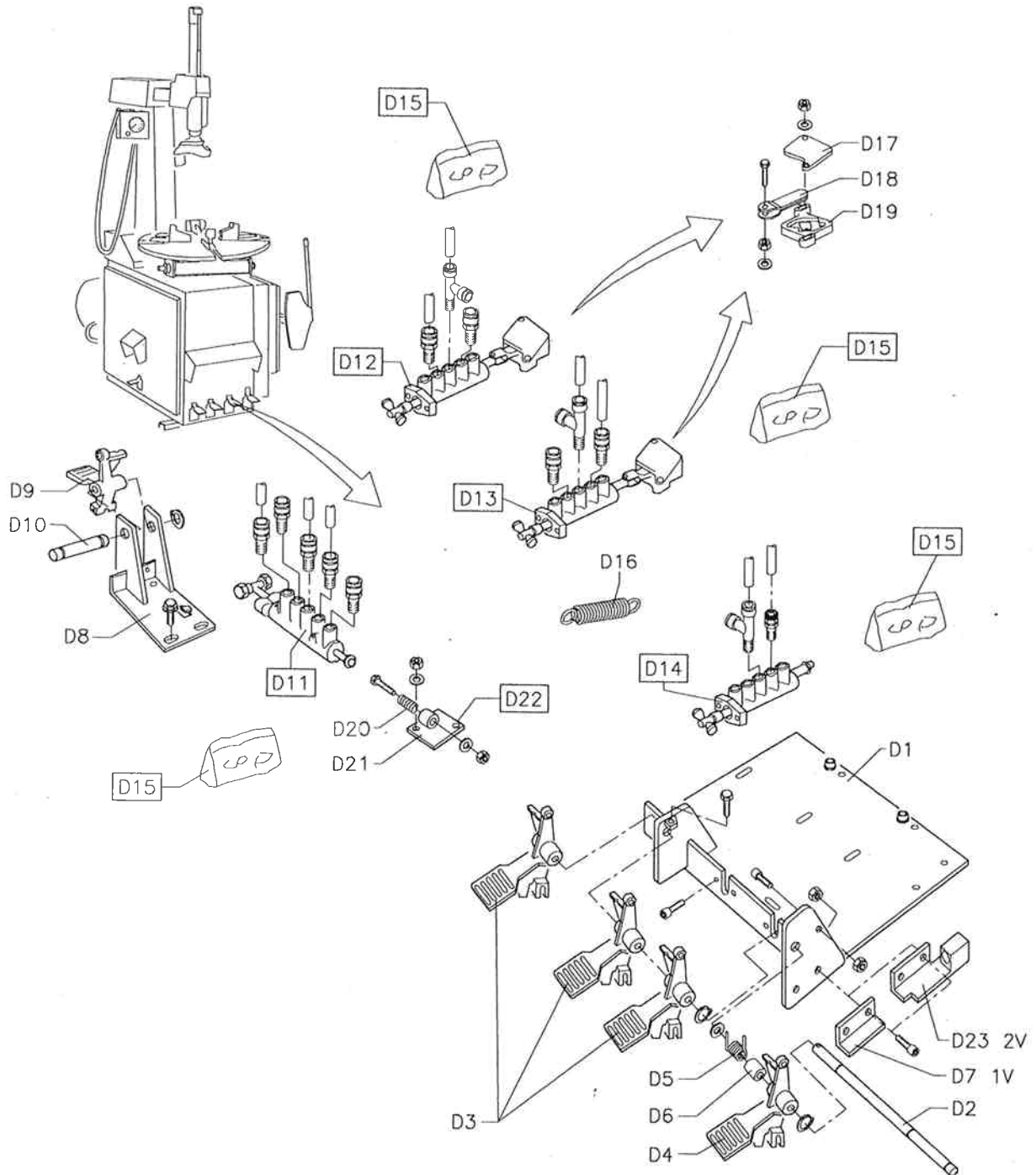



GRUPPO PEDALIERA 1V
PEDAL UNIT 1V
GROUPE PÉDALES 1V
PEDALEINHEIT 1V
GRUPO PÉDALES 1V

AS 942
AS 942 TI
TAV. E

IMPORTANTE: per la richiesta dei ricambi far riferimento al codice ricambi (vedi pag. 16).
IMPORTANT: for the request of spare parts please refer to spare parts code (see page 16).
IMPORTANT: pour la demande de pièces de rechange faire référence au code des pièces de rechange (voir pages 16).
WICHTIG: für die Anforderung von Ersatzteilen die Ersatzteilcodes (siehe Seite 16) angeben.
IMPORTANTE: para pedir los repuestos remitirse al código repuestos (ver pag. 16).

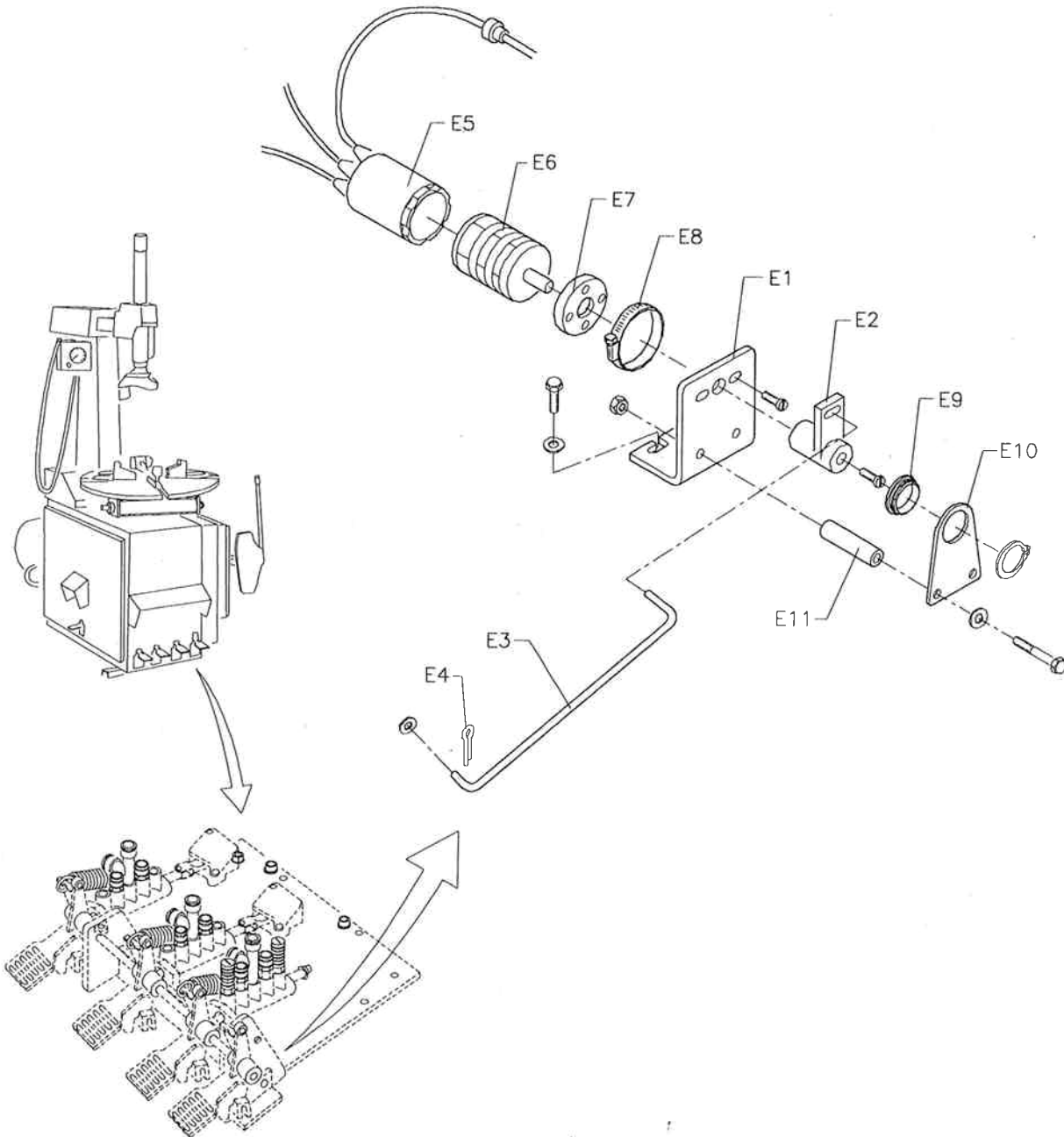



GRUPPO PEDALIERA 2V
PEDAL UNIT 2V
GROUPE PÉDALES 2V
PEDALEINHEIT 2V
GRUPO PEDALES 2V

AS 942
AS 942 TI
TAV. F

IMPORTANTE: per la richiesta dei ricambi far riferimento al codice ricambi (vedi pag. 17).
IMPORTANT: for the request of spare parts please refer to spare parts code (see page 17).
IMPORTANT: pour la demande de pièces de rechange faire référence au code des pièces de rechange (voir pages 17).
WICHTIG: für die Anforderung von Ersatzteilen die Ersatzteilcodes (siehe Seite 17) angeben.
IMPORTANTE: para pedir los repuestos remitirse al código repuestos (ver pag. 17).

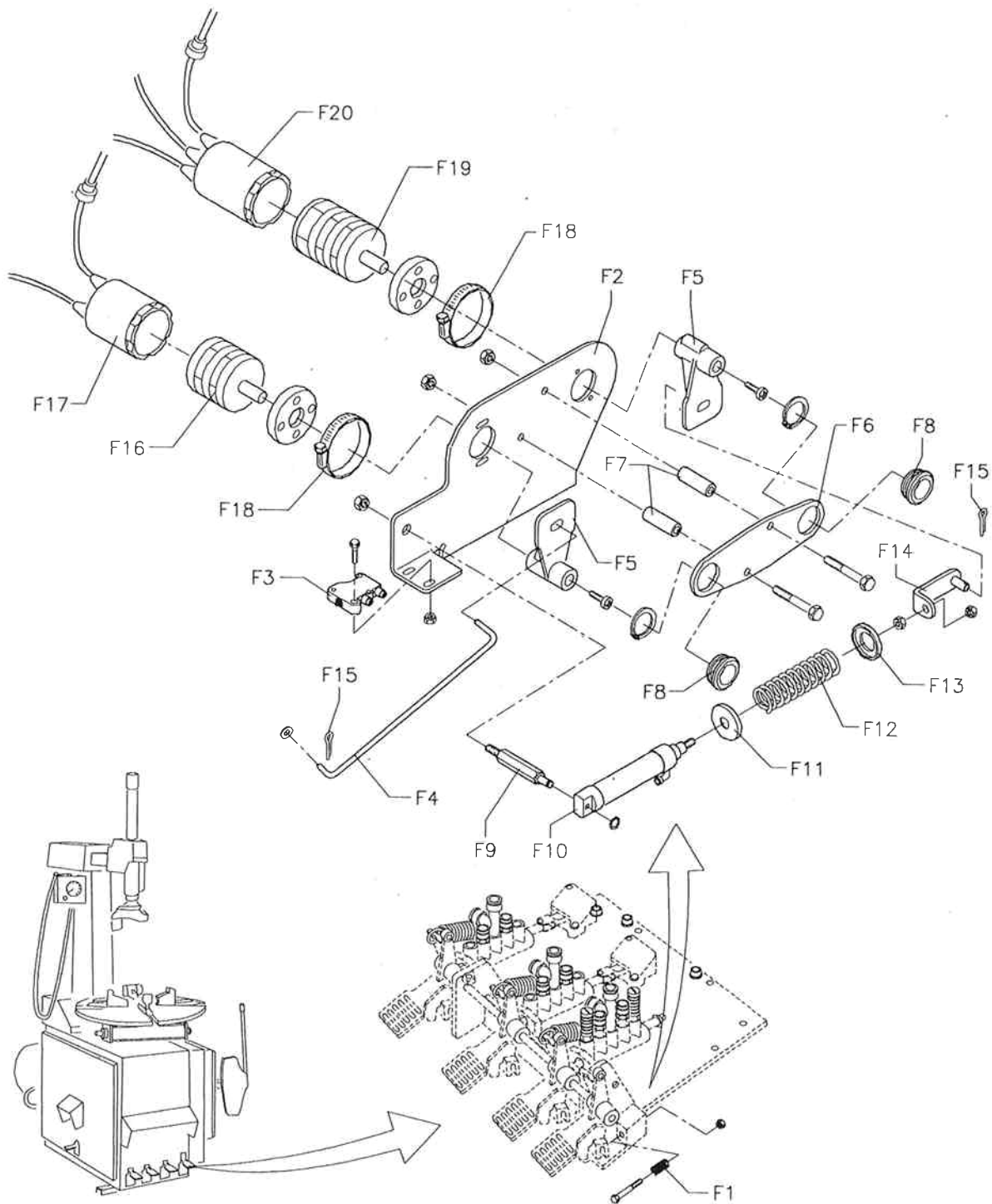



IMPIANTO PNEUMATICO
PNEUMATIC SYSTEM
INSTALLATION PNEUMATIQUE
PNEUMATISCHE ANLAGE
INSTALACION NEUMATICA

AS 942
AS 942 TI
TAV. G

IMPORTANTE: per la richiesta dei ricambi far riferimento al codice ricambi (vedi pag. 17).
IMPORTANT: for the request of spare parts please refer to spare parts code (see page 17).
IMPORTANT: pour la demande de pièces de rechange faire référence au code des pièces de rechange (voir pages 17).
WICHTIG: für die Anforderung von Ersatzteilen die Ersatzteilcodes (siehe Seite 17) angeben.
IMPORTANTE: para pedir los repuestos remitirse al código repuestos (ver pag. 17).

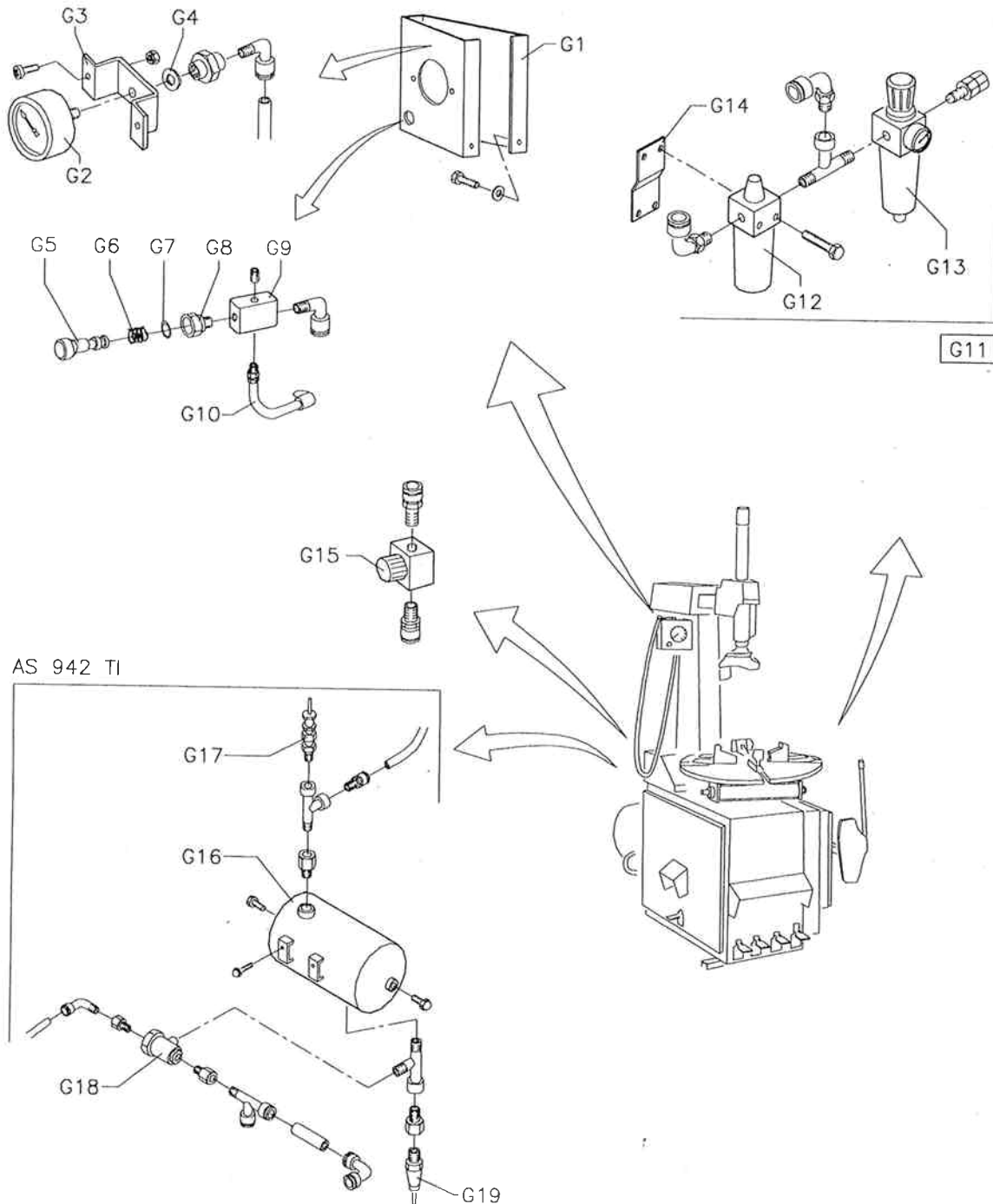



GRUPPO STALLONATORE LATERALE
LATERAL BEAD-BREAKER UNIT
GROUPE ETALONNEUR LATERAL
LATERALE WULSTENTFERNEREINHEIT
GRUPO DESTALONADOR LATERAL

AS 942
AS 942 TI
TAV. H

IMPORTANTE: per la richiesta dei ricambi far riferimento al codice ricambi (vedi pag. 18).
IMPORTANT: for the request of spare parts please refer to spare parts code (see page 18).
IMPORTANT: pour la demande de pièces de rechange faire référence au code des pièces de rechange (voir pages 18).
WICHTIG: für die Anforderung von Ersatzteilen die Ersatzteilcodes (siehe Seite 18) angeben.
IMPORTANTE: para pedir los repuestos remitirse al código repuestos (ver pag. 18).

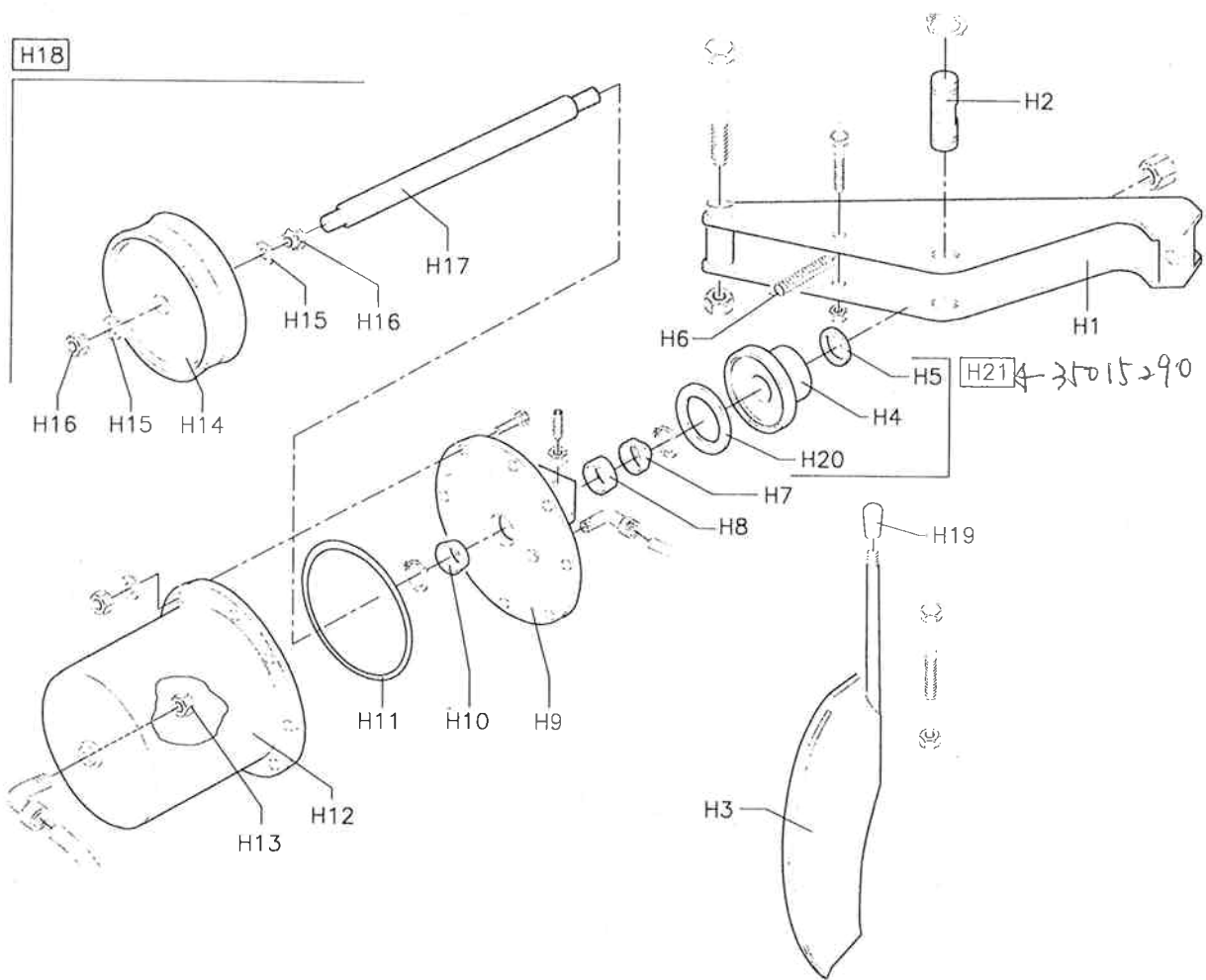



MOTORIDUTTORE
 REDUCTION MOTOR
 MOTORE-DUCTEUR
 GETRIEBEMOTOR
 MOTORIDUCTOR

AS 942
 AS 942 TI
 TAV. I

IMPORTANTE: per la richiesta dei ricambi far riferimento al codice ricambi (vedi pag. 19).
IMPORTANT: for the request of spare parts please refer to spare parts code (see page 19).
IMPORTANT: pour la demande de pièces de rechange faire référence au code des pièces de rechange (voir pages 19).
WICHTIG: für die Anforderung von Ersatzteilen die Ersatzteilcodes (siehe Seite 19) angeben.
IMPORTANTE: para pedir los repuestos remitirse al código repuestos (ver pag. 19).

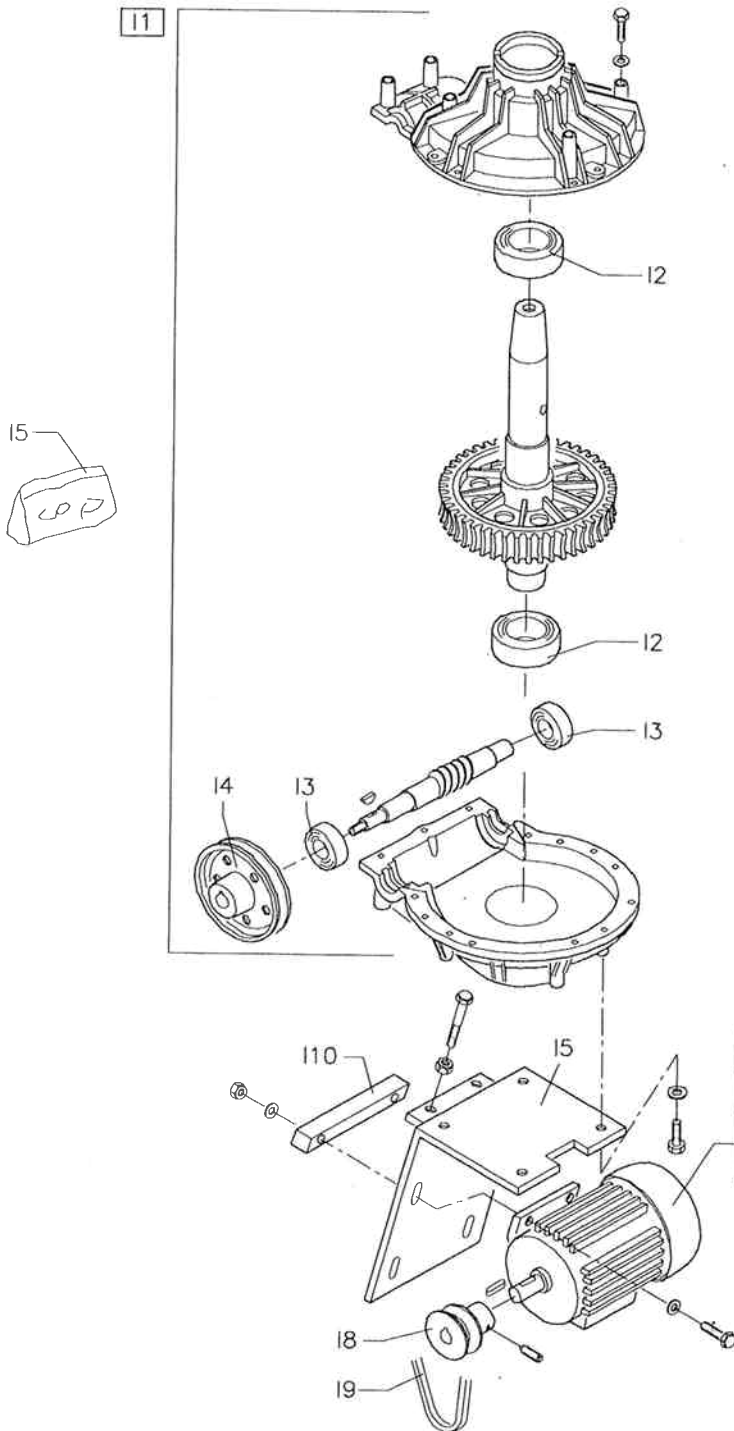

I11	3 phase 380 2V
I12	3 phase 220 2V
I16	3 phase 380/220V 1V
I17	monophase 220/250V 1V

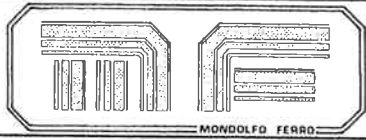

MORSA PNEUMATICA
PNEUMATIC CHUCK
ATEU PNEUMATIQUE
PNEUMATISCHER SCHRAUBSTOCK
GARRAS NEUMATICA

AS 942
AS 942 TI
TAV. L

IMPORTANTE: per la richiesta dei ricambi far riferimento al codice ricambi (vedi pag. 19).
IMPORTANT: for the request of spare parts please refer to spare parts code (see page 19).
IMPORTANT: pour la demande de pièces de rechange faire référence au code des pièces de rechange (voir pages 19).
WICHTIG: für die Anforderung von Ersatzteilen die Ersatzteilcodes (siehe Seite 19) angeben.
IMPORTANTE: para pedir los repuestos remitirse al código repuestos (ver pag. 19).





TABELLA RICAMBI
SPARE PARTS CODE
TABLE PIÈCES DE RECHANGE
ERSATZTEILLISTE
TABLA REPUESTOS

AS 942
AS 942 TI

Posizione Position Position Position Posicion	Codice ricambio Spare parts code Code rechanger Ersatzteilcode Codigo repuesto	Descrizione Description Description Beschreibung Descripción	Posizione Position Position Position Posicion	Codice ricambio Spare parts code Code rechanger Ersatzteilcode Codigo repuesto	Descrizione Description Description Beschreibung Descripción
TAV. A			TAV. B		
A1	34024790	BASAMENTO BASEMENT	B1	34024824	STRUTTURA PIANTONE COLUMN STRUCTURE
A2	36021684	CARTER LATERALE LATERAL SUMP	B2	33011500	PERNO COLUMN CYLINDER UPPER PIN
A3	35011564	PIEDINO FOOT	B3	32011600	CILINDRO SHAFT CLAMPING CYLINDER
A4	35016507	BATTUTA CERCHIO RIM BEAT PLUG	B4	34024828	STRANGOLO LOCKING PLATE
A5	33011565	LEVA CACCIATALLONI BEAD-FASTENER LEVER	B5	33010322	MOLLA SPRING
A6	36025258	CARTER SUMP	B6	34024825	RUOTA STRANGOLO LOCKING WHEEL
A7	33011466	PERNO COLUMN HINGE PIN	B7	34024825	SCORREVOLE ORIZZONTALE HORIZONTAL SLIDING
A8	36024779	SUPPORTO CONTENITORE GRASSO GREASE CONTAINER SUPPORT	B8	85606150	GUARNIZIONE OR 6150 A+P WASHER OR 6150 A+P
A9	87291187	TAPPO RELEASE CAP D30 DP 1187	B9	33020057	ALBERO UTENSILE TOOL SHAFT
A10	36019156	STAFFA SUPPORTO SERBATOIO RESERVOIR SUPPORT FLASK	B10	35020058	DISTANZIALE SPACER
A11	36019152	PASSARACCORDI UNIONS GUIDE	B11	33011507	PIASTRINO ANTISCHIACCIAMENTO ANTI-SQUASHING PLAQUE
A12	32011444	CILINDRO COLUMN TURNOVER CYLINDER	B12	33020437 257877A	UTENSILE INTEGRALE 86 INTEGRAL TOOL 86
A13	33011472	PERNO COLUMN CYLINDER LOWER PIN	B13	32011567 257877A	UTENSILE COMPLETO COMPLETE TOOL KIT
A14	36012326	PIASTRINO MASSES ANCHORING PLAQUE	B14	35023240	PUNTALE UTENSILE PUSH ROD FOR TOOL
A15	36020033	PROTEZIONE COLUMN BACK FENDER	B15	35016713	PUNTALE UTENSILE PUSH ROD FOR TOOL
A16	35018007	CARTER PORTA OGGETTI OBJECT-HOLDER SUMP	B16	35011564	BATTUTA SLIDING STOP PLUG
			B17	33021219	PERNO MANOPOLA KNOB PIN
			B18	87290511	MANOPOLA KNOB 1004/PB-20
			B19	33021218	BOCCOLA SPACER
			B20	35020035	COPERCHIO COP
			B21	34021614	CARTER PLATE
			B22	35020003	COPERCHIO PER CARTER COVER PLATE
			B23	32020007	CILINDRO SOLL. UTENSILE TOOL LIFTING CYLINDER

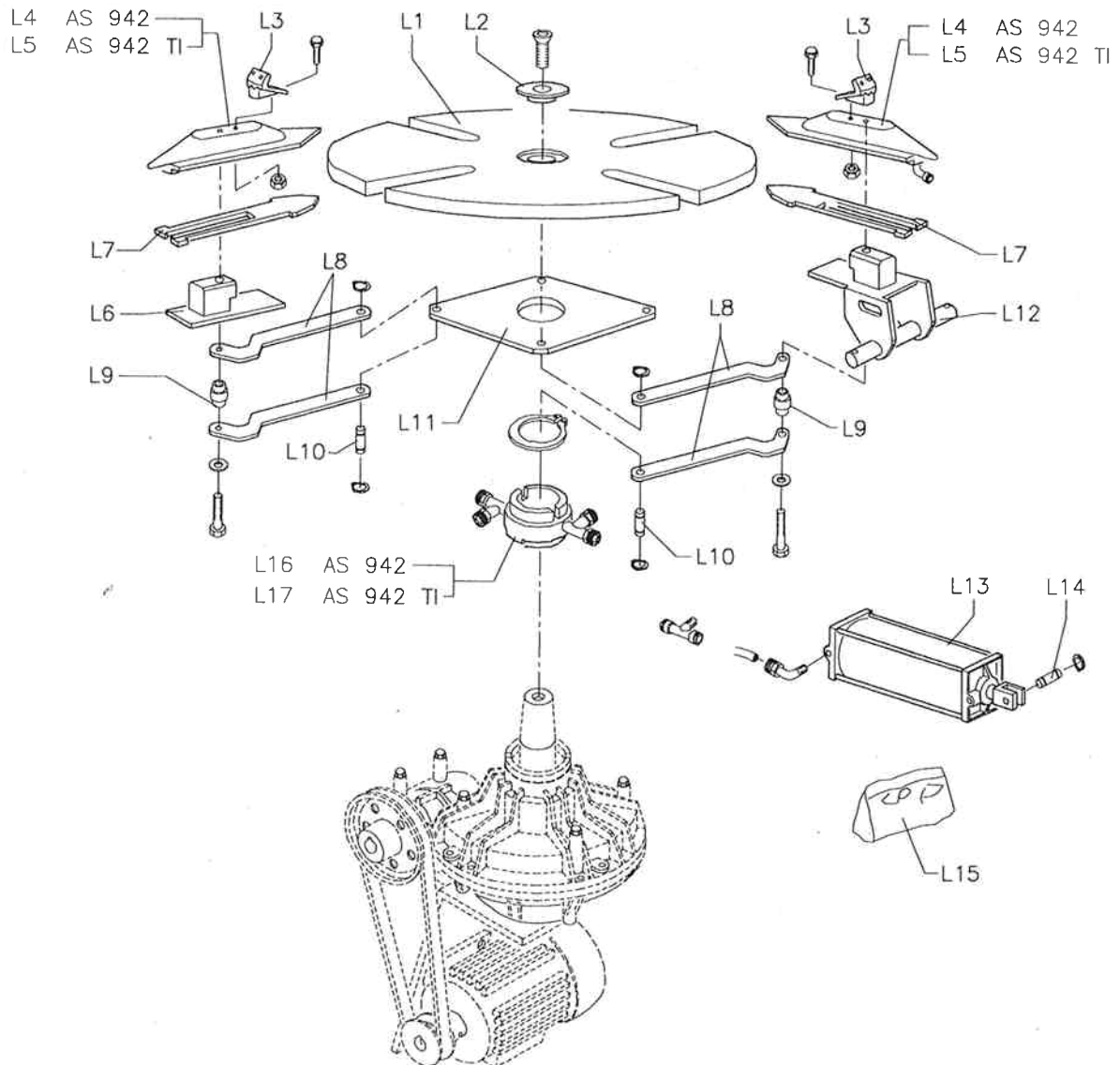

TABELLA RICAMBI
 SPARE PARTS CODE
 TABLE PIECES DE RECHANGE
 ERSATZTEILLISTE
 TABLA REPUESTOS

AS 942
 AS 942 TI

Posizione Position Position Position Posicion	Codice ricambio Spare parts code Code rechanger Ersatzteilcode Codigo repuesto	Descrizione Description Description Beschreibung Descripción	Posizione Position Position Position Posicion	Codice ricambio Spare parts code Code rechanger Ersatzteilcode Codigo repuesto	Descrizione Description Description Beschreibung Descripción
B24	34021590	STRANGOLO ANTERIORE FRONT LOCKING PLATE	TAV. C		
B25	33014557	MOLLA VERTICAL SHAFT UPPER SPRING	C1	35011363	PISTONE SLIDING CLAMPING CYLINDER PISTON
B26	35020034	PASSATUBI PIPE SUPPORT	C2	85500020	GUARNIZIONE DEM-63 A+P WASHER DEM-63 A+P
B27	35015568	MORSETTO CLAMP	C3	33011364	CANNA CILINDRO SHAFT CLAMPING CYLINDER LINER
B28	85100011	VALVOLA CLAMPING CYLINDER CONTROL VALVE	C4	33011448	OCCHIELLO COLUMN CYLINDER EYELET
B29	33021216	MOLLA SPRING	C5	33011447	STELO CILINDRO PIANTONE COLUMN CYLINDER STEM
			C6	85600108	GUARNIZIONE OR 108 A+P WASHER OR 108 A+P
			C7	33011182	PISTONE COLUMN CYLINDER PISTON
			C8	85606212	GUARNIZIONE OR 6212 A+P WASHER OR 6212 A+P
			C9	85500007	GUARNIZIONE DI-062 A+P WASHER DI-062 A+P
			C10	33011501	FONDELLO ANTERIORE COLUMN CYLINDER FRONT BOTTOM
			C11	85600162	GUARNIZIONE OR 162 A+P WASHER OR 162 A+P
			C12	33011446	CANNA CILINDRO PIANTONE COLUMN CYLINDER BARREL
			C13	33011445	TIRANTE CILINDRO PIANTONE COLUMN CYLINDER STAY BOLT
			C14	33011504	FONDELLO POSTERIORE COLUMN CYLINDER BACK BOTTOM



TABELLA RICAMBI
SPARE PARTS CODE
TABLE PIECES DE RECHANGE
ERSATZTEILLISTE
TABLA REPUESTOS

AS 942
AS 942 TI

Posizione Position Position Position Posicion	Codice ricambio Spare parts code Code rechanger Ersatzteilcode Codigo repuesto	Descrizione Description Description Beschreibung Descripción	Posizione Position Position Position Posicion	Codice ricambio Spare parts code Code rechanger Ersatzteilcode Codigo repuesto	Descrizione Description Description Beschreibung Descripción
TAV. D			TAV. E		
D1	34025255	SUPPORTO PEDALIERA COMPLETE PEDAL-CONTROLS	E1	34011313	SUPPORTO INVERTITORE REVERSER SUPPORT
D2	33019219	ASTA FOOT-LEVERS REST ROD	E2	35008588A	SNODO INVERTITORE ARTICULATION REVERSER
D3	33011309	PEDALE DIE-CAST FOOT-LEVER	E3	36011326	BIELLA INVERTITORE POLE REVERSER CONNECTING ROD
D4	33020303	PEDALE DIE-CAST FOOT-LEVER	E4	33018515	COPIGLIA SLIT PIN
D5	33008575	MOLLA INVERTITORE REVERSER SPRING	E5	35011627	PROTEZIONE INVERTITORE REVERSER FENDER
D6	33011330	DISTANZIALE REVERSER SPRING SPACER	E6	84710001	INVERTITORE 1°V INVERTER 1°V
D7	34020072	STAFFA BRACKET	E7	84990017	SCODELLINO INVERTITORE POLE REVERSER CUP
D8	36019307	SUPPORTO PEDALE FOOT-LEVER REST	E8	81905470	FASCETTA MIKALOR REGULAR 54-70 DIN 301 CLAMP MIKALOR REGULAR 54-70 DIN 301
D9	33014485	PEDALE FOOT-LEVER	E9	35015167	BOCCOLA BUSH
D10	33019303	PERNO FOOT-LEVER REST PIN	E10	36025259	FLANGIA FLANGE
D11	32020684	VALVOLA GONFIAGGIO INFLATING VALVE	E11	33017249	DISTANZIALE SPACER
D12	32020680	VALVOLA PIANTONE *KIT COMPLETE COLUMN VALVE KIT			
D13	32020681	VALVOLA MORSA *KIT CHUCK VALVE			
D14	32020707	VALVOLA STALLONATORE *KIT BEAD-BREAKER VALVE KIT			
D15	86518405	KIT GUARNIZIONI WASHERS KIT			
D16	34010279	MOLLA FOOT-LEVER TRACTIVE SPRING			
D17	36011324	COPERCHIO SELETTORE CAP SELECTOR			
D18	36011325	BIELLA SELETTORE SELECTOR ROD			
D19	33011308	SELETTORE SELECTOR			
D20	33008585	MOLLA DOPPIO SNODO DOUBLE ARTICULATION			
D21	36013326	SUPP. DISPOSITIVO SELECTOR SUPPORT			
D22	31100072	DISPOSITIVO GONFIATUB. GONFIATUB. SELECTOR			
D23	36024841	STAFFA BRACKET			



TABELLA RICAMBI
SPARE PARTS CODE
TABLE PIECES DE RECHANGE
ERSATZTEILLISTE
TABLA REPUESTOS

AS 942
AS 942 TI

Posizione Position Position Position Posicion	Codice ricambio Spare parts code Code rechanger Ersatzteilcode Codigo repuesto	Descrizione Description Description Beschreibung Descripción	Posizione Position Position Position Posicion	Codice ricambio Spare parts code Code rechanger Ersatzteilcode Codigo repuesto	Descrizione Description Description Beschreibung Descripción
TAV. F			TAV. G		
F1	34011313	MOLLA SPRING	G1	34018010	SCATOLA MANOMETRO MANOMETER HOLDER BOX
F2	34024840	SUPPORTO INVERTITORE REVERSER SUPPOR	G2	85100049	MANOMETRO MANOMETER
F3	3-00385	VALVOLA VALVE	G3	36015423	STAFFA MANOMETER REST CLIP
F4	36011326	BIELLA INVERTITORE POLE REVERSER CONNECTING ROD	G4	85500016	GUARNIZIONE ALLUMINIO 1/4" WASHER ALUMINIUM 1/4"
F5	35008588A	SNODO INVERTITORE ARTICULATION REVERSER	G5	33015477	PULSANTE RELIEF PUSH-BUTTON
F6	34025261	FLANGIA FLANGE	G6	33009805	MOLLA VALVE SPRING
F7	33017249	DISTANZIALE SPACER	G7	85602015	GUARNIZIONE OR 2015 A+P WASHER OR 2015 A+P
F8	35015167	BOCCOLA BUSH	G8	33015475	RACCORDO PULSANTE MANOMETER MANOMETER PUSH-BUTTON UNION
F9	33024844A	PERNO PIN	G9	85200066	RACCORDO CROCE 1/4" F.150.4 CROSS UNION 1/4" F.150.4
F10	85400008	CILINDRO CYLINDER	G10	85100038	TUBO GONF. 1/4 L.1500 CL. 27 PUMPING PIPE 1/4 L.1500 CL. 27
F11	35024932	SCODELLINO CUP	G11	31500079	GRUPPO LUBRIFICATORE + REGOLATORE PRESSIONE LUBRICATION UNIT + PRESSURE REGULATOR
F12	33022690	MOLLA SPRING	G12	85100002	LUBRIFICATORE ARIA 1/4" L14MD AIR LUBRICATOR 1/4" L14MD
F13	35022279	SCODELLINO CUP	G13	85100059	REGOLATORE PRESSIONE 0-10 PRESSURE REGULATOR 0-10
F14	36023335	FORCELLA FORK	G14	36020603	SUPPORTO SUPPORT
F15	33018515	COPIGLIA SLIT PIN	G15	85100074	VALVOLA DG020 VALVE DG020
F16	84710001	INVERTITORE REVERSER	G16	36015457	SERBATOIO ARIA AIR RESERVOIR
F17	35011627	PROTEZIONE INVERTITORE REVERSER GUARD	G17	85100064	VALVOLA DI SICUREZZA 1/4" 8-12 SAFE VALVE 1/4" 8-12
F18	84990079	FASCETTA CLAMP	G18	85100033	VALVOLA SCARICO RAPIDO QUICK UNLOADING RAPID VALVE
F19	84710023	DEVIATORE SHUNT	G19	85200149	RACCORDO SCARICO UNLOADING UNION
F20	35016098	PROTEZIONE DEVIATORE SHUNT GUARD			
	32024332	CAVO INVERTITORE /DEVIATORE REVERSER/SHUNT CABLE			



TABELLA RICAMBI
SPARE PARTS CODE
TABLE PIÈCES DE RECHANGE
ERSATZTEILLISTE
TABLA REPUESTOS

AS 942
AS 942 TI

Posizione Position Position Position Posicion	Codice ricambio Spare parts code Code rechanger Ersatzteilcode Codigo repuesto	Descrizione Description Description Beschreibung Descripción	Posizione Position Position Position Posicion	Codice ricambio Spare parts code Code rechanger Ersatzteilcode Codigo repuesto	Descrizione Description Description Beschreibung Descripción
TAV. H					
H1	34018691	BRACCIO STALLONATORE BEAD-BREAKER ARM	H18	31500081	CILINDRO STALLONATORE BEAD-BREAKER CYLINDER
H2	34024906	PERNO BEAD-BREAKER ARM CONTROL PIN	H19	87221102	IMPUGNATURA I.222/40-M10 HANDLE I.222/40-M10
H3	34024640	PALA STALLONATORE LATERAL BEAD-BREAKER BLADE	H20	35015286	FINECORSA BEAD-BREAKER STOP SHOCKPROOF PLUG
H4	33015258	DISTANZIALE FINECORSA STALLONATORE BEAD-BREAKER ARM ENDSTROKE SPACER	H21	35015290	FINECORSASTALLONATORE LATERALE LATERAL BEAD-BREAKER ENDSTROKE
H5	35015259	FINECORSASTALLONATORE BEAD-BREAKER STOP SHOCKPROOF PLUG			
H6	33016602	MOLLA BEAD-BREAKER ARM TRACTIVE SPRING			
H7	85500040	GUARNIZIONE RM 2030 A+P WASHER RM 2030 A+P			
H8	85500039	GUARNIZIONE I/DWR 20/2 POLYPAC WASHER I/DWR 20/2 POLYPAC			
H9	33014026	FONDELLO CILINDRO BEAD-BREAKER CYLINDER BOTTOM			
H10	85500005	GUARNIZIONE B110078 P./D110078 A+P WASHER B110078 P./D110078 A+P			
H11	85604750	GUARNIZIONE OR 4750 A+P WASHER OR 4750 A+P			
H12	36014060	CANNA CILINDRO DRAWN PNEUMATIC CYL. LINER			
H13	85900010	GHIERA 1/4 CL.1253 (CONTRO-DADO) RING NUT 1/4 CL.1253 (LOCK NUT)			
H14	3-80018	PISTONE MONOBLOCCO PM200-27 D20 ENBLOCK PISTON PM200-27 D20			
H15	36019033	ROND. SPESS. 28x65x1 WASHER THICK. 28x65x1			
H16	33014137	GHIERA CILINDRO BEAD-BREAKER CYLINDER RING NUT			
H17	33014448	STELO CILINDRO BEAD-BREAKER CYLINDER STEM			



TABELLA RICAMBI
SPARE PARTS CODE
TABLE PIECES DE RECHANGE
ERSATZTEILLISTE
TABLA REPUESTOS

AS 942
AS 942 TI

Posizione Position Position Position Posicion	Codice ricambio Spare parts code Code rechanger Ersatzteilcode Codigo repuesto	Descrizione Description Description Beschreibung Descripción	Posizione Position Position Position Posicion	Codice ricambio Spare parts code Code rechanger Ersatzteilcode Codigo repuesto	Descrizione Description Description Beschreibung Descripción
TAV. I			TAV. L		
I1	9-00031	RIDUTTORE AQUILA *KIT <i>AQUILA REDUCTION GEAR</i>	L1	34024831	DISCO MORSA PNEUMATICA <i>PNEUMATIC CHUCK PLATE</i>
I2	2-01220	CUSCINETTO RADIALE <i>RADIAL BEARING</i>	L2	33011187	RONDELLA <i>WASHER</i>
I3	88830204	CUSCINETTO RULLI CONICI <i>CONICAL ROLLER BEARING</i>	L3	33010711	UNGHIA MORSA PNEUMATICA <i>PNEUMATIC CHUCK NAIL</i>
I4	33019174	PULEGGIA <i>AQUILA REDUCTION GEAR BELT PULLEY</i>	L4	34020434	PATTINO MORSA PNEUMATICA AS 942 <i>PNEUMATIC CHUCK SLIDING BLOCK AS 942</i>
I5	36021690	SUPPORTO MOTORE <i>REDUCTION MOTOR REST</i>	L5	36020050	PATTINO MORSA PNEUMATICA AS 942 TI <i>PNEUMATIC CHUCK SLIDING BLOCK AS 942 TI</i>
I6	3-00968	MOTORE ELETTRICO TRIFASE P-4 B3 380/220V/50Hz <i>THREE PHASE ELECTRIC MOTOR P-4 B3 380/220V/50Hz.</i>	L6	34024834	BASE PATTINO <i>SLIDING BLOCK BASE</i>
I7	3-01094	MOTORE EL. MONOFASE P4 1 <i>MONO PHASE EL. MOTOR</i>	L7	36020049	COPERTURA ASOLA <i>STEEL PLATE</i>
I8	33019200	PULEGGIA MOTORE <i>MOTOR BELT PULLEY</i>	L8	34018482	BIELLA <i>CONNECTING ROD</i>
I9	3-00593	CINGHIA TRAPEZOIDALE A 23,5 V BELT A 23,5	L9	33010715	BOCCOLA <i>ROD BUSH</i>
I10	33021693	BARRA REGOLAZIONE MOTORE <i>ADJUSTMENT MOTOR BRACKET</i>	L10	34010718	PERNO <i>PIN</i>
I11	83833308	MOTORE ELETTRICO TRIFASE P2-4 B3 380V 50Hz 0,8-1 <i>THREE PHASE ELECTRIC MOTOR P2-4 B3 380V 50Hz 0,8-1</i>	L11	36018481	PIASTRA INFERIORE <i>LOWER PLATE</i>
I12	83833208	MOTORE ELETTRICO TRIFASE P2-4 B3 220V 50Hz 0,8-1 <i>THREE PHASE ELECTRIC MOTOR P2-4 B3 220V 50Hz 0,8-1</i>	L12	34024835	STAFFA <i>CONNECTION CLIP</i>
			L13	32024770	CILINDRO <i>CYLINDER</i>
			L14	33011185	PERNO <i>PIN</i>
			L15	85524770	KIT GUARNIZIONI <i>WASHERS KIT</i>
			L16	32019316	GRUPPO DISTRIBUTORE ROTANTE AS 942 <i>ROTATING DISTRIBUTOR UNIT AS 942</i>
			L17	32019317	GRUPPO DISTRIBUTORE ROTANTE AS 942 TI <i>ROTATING DISTRIBUTOR UNIT AS 942 TI</i>



MONDOLFO FERRO S.p.a.

Viale dell'Industria, 20 - 61037 MONDOLFO (PU) Italy

Tel. 0721.93671 - Fax 0721.930238

export.dpt@mondolfoferro.it

commitalia@mondolfoferro.it

www.mondolfoferro.it

0703

