

*Production 04/2013 - Code 4-104323E*



I

Sul presente documento sono stati indicati in grassetto i codici che sono variati rispetto a quelli riportati nella precedente versione del 09/12

En

Codes that have changed from those given in the previous version dated 09/12 are indicated in bold type in this document

De

Die gegenüber der Vorgängerversion vom 09/12 geänderten Codes sind im vorliegenden Dokument fettgedruckt angegeben

Fr

Ce document reporte en gras les codes qui ont été modifiés par rapport à ceux reportés dans la version précédente du mois de 09/12

**IMPORTANTE:** per la richiesta dei ricambi far riferimento al codice ricambi (vedi pag. 18).  
**IMPORTANT:** for the request of spare parts please refer to spare parts code (see page 18).  
**IMPORTANT:** pour la demande de pièces de rechange faire référence au code des pièces de rechange (voir pages 18).  
**WICHTIG:** für die Anforderung von Ersatzteilen die Ersatzteilkodes (siehe Seite 18) angeben.  
**IMPORTANTE:** para pedir los repuestos remitirse al código repuestos (ver pag. 18).

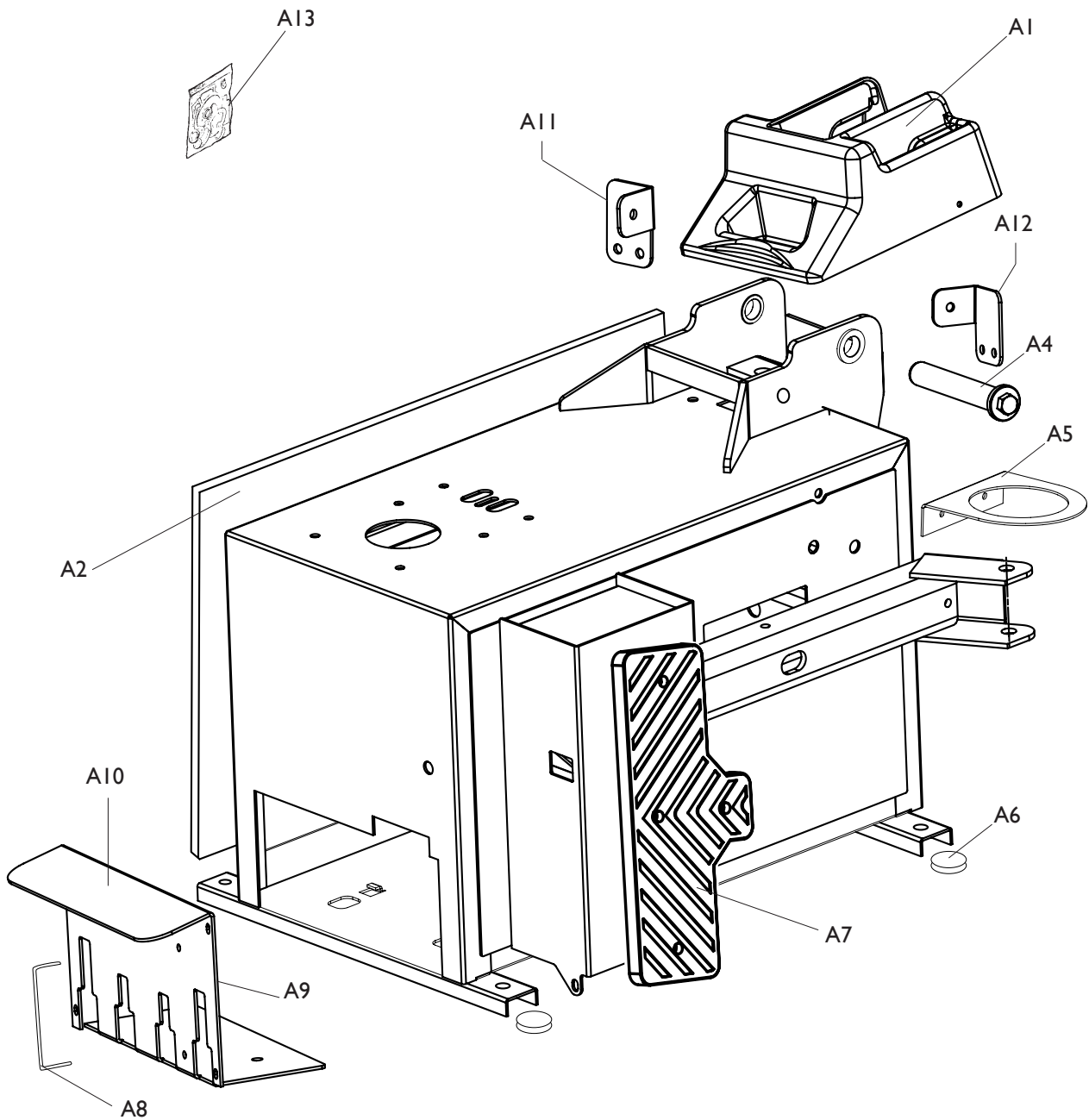



CASSA  
BODY  
CAISSE  
GEHÄUSE  
CAJA

**AS 933**  
**TAV. A**

A1	4-102137	PROTEZIONE	SHIELD
A2	5-100884	COFANO+ADESIVI	HOOD
A4	4-102365	PERNO	PIN
A5	326169	SUPPORTO	SUPPORT
A6	35011564	PIEDE	FOOT
A7	35016507	APPOGGIO	RIM SUPPORT
A8	346545	PROTEZIONE	SHIELD
A9	4-102260	PROTEZIONE	SHIELD
A10	35019950	AD.PEDALIERA 1V	LABEL
A10	35020887	AD.PEDALIERA 2V	LABEL
A11	4-102347	STAFFA SX	BRACKET
A12	4-102348	STAFFA DX	BRACKET
<b>A13</b>	<b>5-105860</b>	<b>KIT ADESIVI AS933</b>	<b>LABEL KIT AS933</b>

**IMPORTANTE:** per la richiesta dei ricambi far riferimento al codice ricambi (vedi pag. 18).  
**IMPORTANT:** for the request of spare parts please refer to spare parts code (see page 18).  
**IMPORTANT:** pour la demande de pièces de rechange faire référence au code des pièces de rechange (voir pages 18).  
**WICHTIG:** für die Anforderung von Ersatzteilen die Ersatzteilkodes (siehe Seite 18) angeben.  
**IMPORTANTE:** para pedir los repuestos remitirse al código repuestos (ver pag. 18).

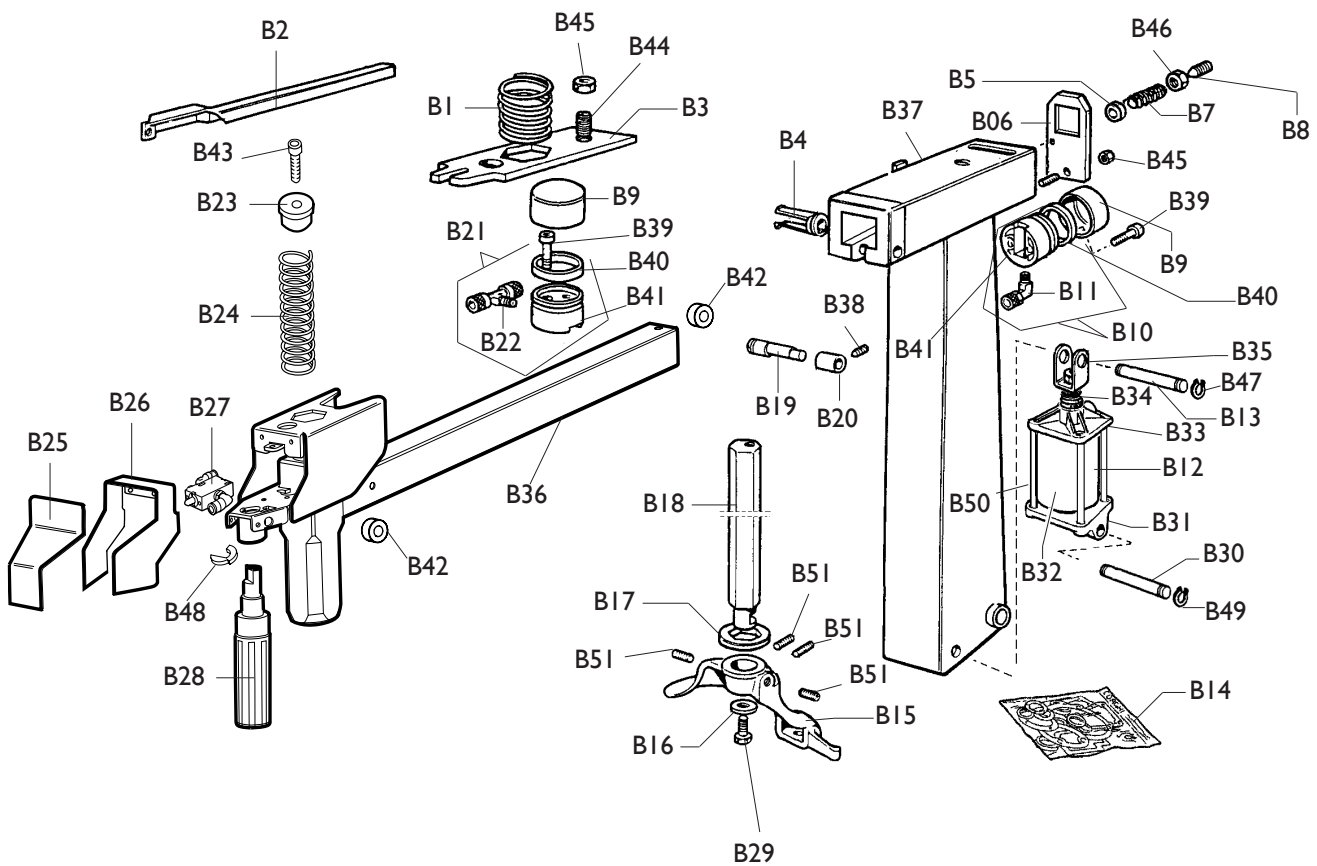



PIANTONE, ALBERO ORIZZONTALE, ALBERO VERTICALE  
 COLUMN, HORIZONTAL SHAFT, VERTICAL SHAFT  
 MONTANT, ARBRE HORIZONTAL, ARBRE VERTICAL  
 SÄULE, HORIZONTAL WELLE, VERTIKALE WELLE  
 PLANCHA, ARBOL HORIZONTAL, ARBOL VERTICAL

**AS 933**  
**TAV. B**

B1	463167	MOLLA	SPRING
B2	426763	GUIDA	GUIDE
B3	4-102002	PIASTRA	SLAB
B4	431061	BOCCOLA	BUSHING
B5	339803	BOCCOLA	BUSHING
B6	336142	PIASTRA	SLAB
B7	439787	MOLLA	SPRING
B8	341836	VITE	SCREW
B9	326537	CILINDRO	CYLINDER
B10	239805	PISTONE	PISTON
B11	3-00106	RACCORDO	CONNECTOR
B12	5-100564	CILINDRO ALZAPALO	CYLINDER
B13	4-102370	PERNO SUP.	PIN
B14	241484	KIT GUARNIZIONI	SEAL KIT
B15	5-104101	TORRETTA	HEAD
B16	350194	RONDELLA	WASHER
B17	428681	ANELLO	RING
B18	4-103207	BRACCIO	ARM
B19	339786	PERNO	PIN
B20	339782	RULLO	ROLLER
B21	239806	PISTONE	PISTON
B22	3-00119	RACCORDO	CONNECTOR
B23	35014525	POMOLO	KNOB
B24	33014186	MOLLA	SPRING
B25	35020003	CARTER	CARTER
B26	4-102234	CARTER	CARTER
B27	5-100777	VALVOLA	VALVE
B28	5-100901	MANIGLIA COMANDO	LOCKING HANDLE
B29	350197	VITE	SCREW
B30	344989	PERNO INF.	PIN
B31	4-115956	FLANGIA POST.	FLANGE
B32	4-101990	CAMICIA	LINER
B33	5-105114	FLANGIA ANT.	FLANGE
B34	4-115982	STELO	ROD
B35	4-115954	CAVALLOTTO	SUPPORT
B36	4-102868	BRACCIO ORIZZONTALE	ARM
B37	4-102262	PALO	POST
B38	2-00542	VITE M6X6	SCREW
B39	2-00314	VITE M6X40	SCREW
B40	443078	GUARNIZIONE	GASKET
B41	443077	PISTONE	PISTON
B42	383372	FERMO	STOP
B43	2-80020	VITE M10X40	SCREW
B44	2-01291	VITE M10X25	SCREW
B45	2-00157	DADO M10	NUT
B46	2-00158	DADO M12	NUT
B47	2-01130	SEEGER D.16	SEEGER
B48	4-104241	FINECORSA MANIGLIA	LIMIT
B49	2-00047	COPIGLIA D.3X30	PLUG
B50	4-115983	TIRANTE	TIEROD
<b>B51</b>	<b>2-71357</b>	<b>VITE M12X16</b>	<b>SCREW</b>

**IMPORTANTE:** per la richiesta dei ricambi far riferimento al codice ricambi (vedi pag. 19).  
**IMPORTANT:** for the request of spare parts please refer to spare parts code (see page 19).  
**IMPORTANT:** pour la demande de pièces de rechange faire référence au code des pièces de rechange (voir pages 19).  
**WICHTIG:** für die Anforderung von Ersatzteilen die Ersatzteilcodes (siehe Seite 19) angeben.  
**IMPORTANTE:** para pedir los repuestos remitirse al código repuestos (ver pag. 19).

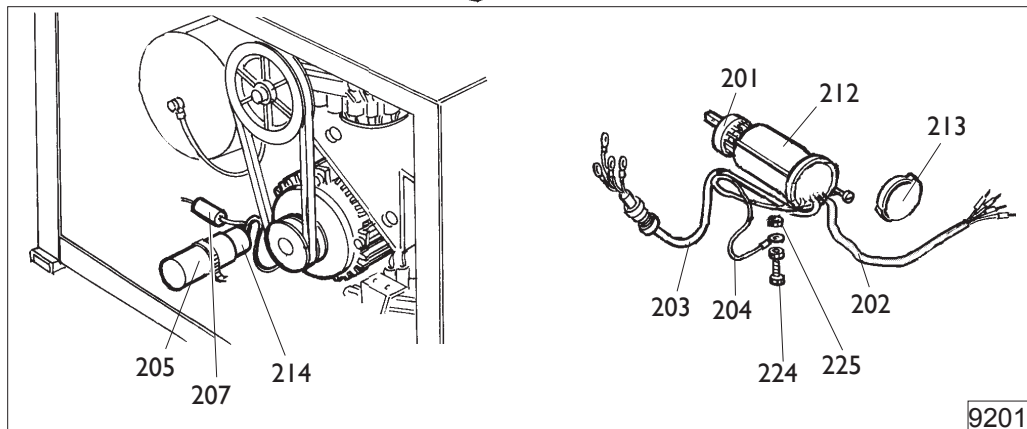
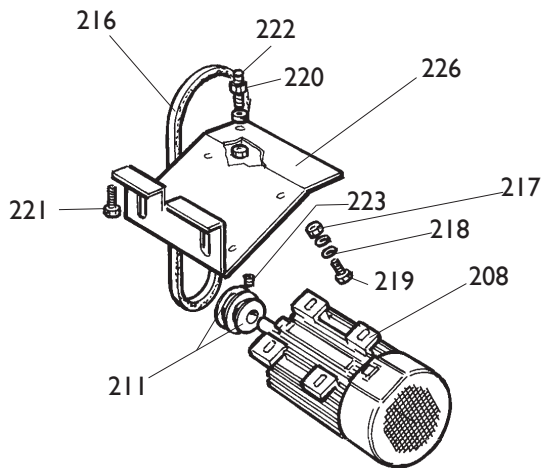

9201





**IMPIANTO ELETTRICO + MOTORE**  
**ELECTRIC SYSTEM + MOTOR**  
**EQUIPEMENT ELECTRIQUE + MOTEUR**  
**ELEKTRISCHE ANLAGE + MOTOR**  
**INSTALACION ELECTRICA + MOTOR**

**AS 933**  
**TAV. C**

IMPIANTO ELETTRICO

ELECTRIC SYSTEM

9201	5-103989	110V 1PH CSA	110V 1PH CSA
0201	5-102741	INVERTITORE	REVERSER
0202	447801	CAVO RETE	CABLE
0203	249590	CAVO MOTORE	CABLE
0204	249601	CAVALLOTTO	U-BOLT
0205	430750	CAPPELLOTTO	CAP NUT
0207	430770	RESISTENZA	RESISTANCE
0214	4-112706	CONDENSATORE	CAPACITOR
0224	2-00605	VITE M4X10	SCREW
0225	2-00143	DADO M4	NUT

9201	249882	110V 1PH	110V 1PH
0201	5-102742	INVERTITORE	REVERSER
0202	230709	CAVO RETE	CABLE
0203	225419	CAVO MOTORE	CABLE
0204	249601	CAVALLOTTO	U-BOLT
0205	430750	CAPPELLOTTO	CAP NUT
0207	430770	RESISTENZA	RESISTANCE
0214	449751	CONDENSATORE	CAPACITOR
0224	2-00605	VITE M4X10	SCREW
0225	2-00143	DADO M4	NUT

9201	235574	3PH	3PH
0201	5-102742	INVERTITORE	REVERSER
0202	447801	CAVO RETE	CABLE
0203	249590	CAVO MOTORE	CABLE
0204	249601	CAVALLOTTO	U-BOLT
0224	2-00605	VITE M4X10	SCREW
0225	2-00143	DADO M4	NUT

MOTORE

MOTOR

0208	422013	3ph 230/400V	3ph 230/400V
0208	425397	3ph 240/440V	3ph 240/440V
0208	4-115122	1ph 230V 50Hz	1ph 230V 50Hz
0208	449748	1ph 230V 60Hz	1ph 230V 60Hz
0208	4-112454	1ph 110V 60Hz	1ph 110V 60Hz

0226	334768	CULLA	CRADLE
0211	331067	PULEGGIA	PULLEY
0212	432065	PROTEZIONE	SHIELD
0213	430991	COPERCHIO	LID
0216	3-00555	CINGHIA	BELT
0217	421349	DADO M8	NUT
0218	339208	RONDELLA M8	WASHER
0219	2-00374	VITE M8X25	SCREW
0220	2-00152	DADO M10	NUT
0221	2-00328	VITE M10X20	SCREW
0222	455920	VITE SPEC M10X60	SCREW
0223	2-01091	VITE M6X5	SCREW

**IMPORTANTE:** per la richiesta dei ricambi far riferimento al codice ricambi (vedi pag. 20).  
**IMPORTANT:** for the request of spare parts please refer to spare parts code (see page 20).  
**IMPORTANT:** pour la demande de pièces de rechange faire référence au code des pièces de rechange (voir pages 20).  
**WICHTIG:** für die Anforderung von Ersatzteilen die Ersatzteilcodes (siehe Seite 20) angeben.  
**IMPORTANTE:** para pedir los repuestos remitirse al código repuestos (ver pag. 20).

9550

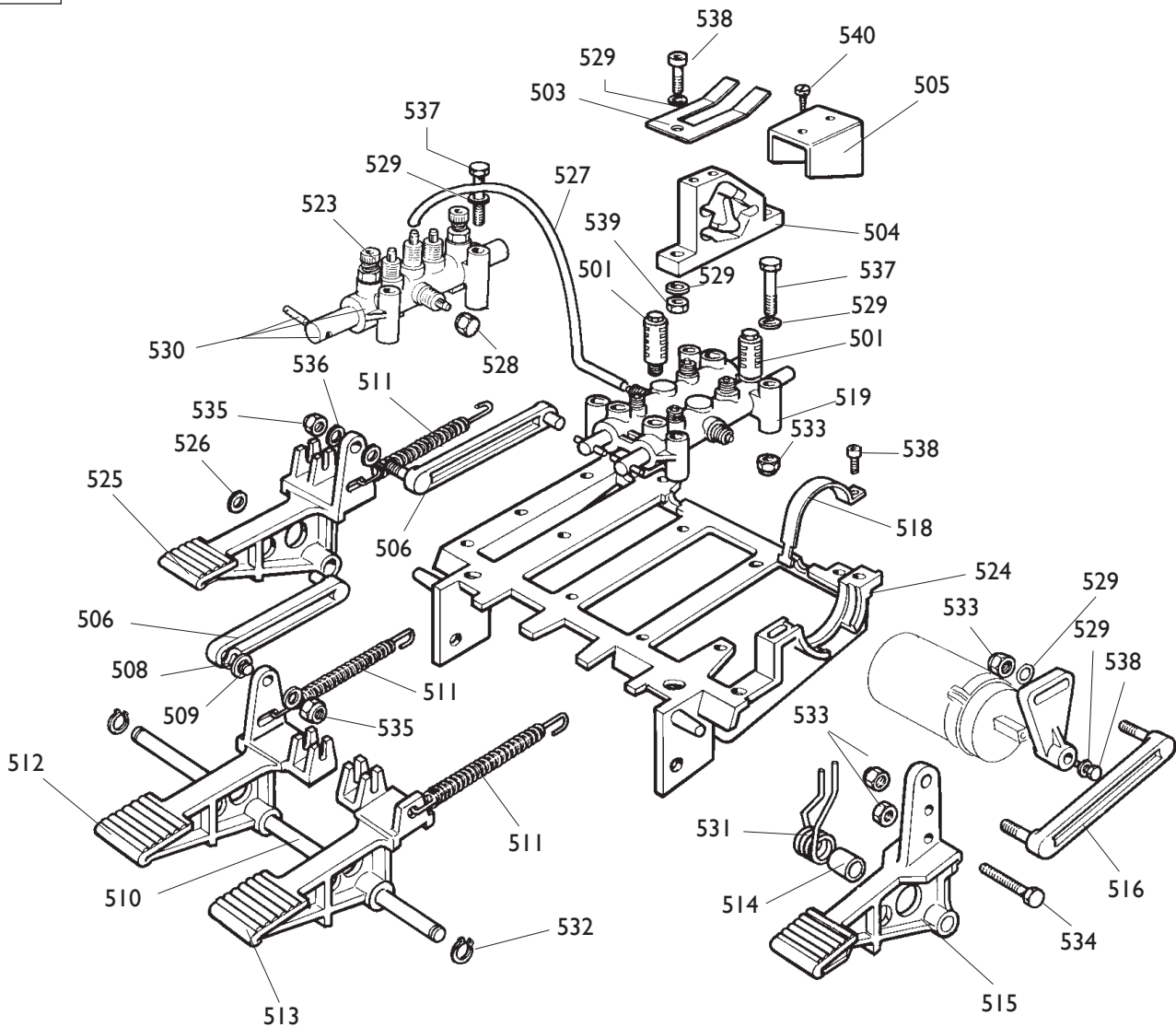



GRUPPO PEDALIERA  
PEDAL UNIT  
GROUPE PEDALES  
PEDALEINHET  
GRUPO PEDALES

AS 933  
TAV. D

9550	233678	PEDALIERA COMPLETA	COMPLETE CONTROL PEDAL
<b>9550</b>	<b>5-100714</b>	<b>PEDALIERA MOTOINVERTER</b>	<b>MOTOINV. CONTROL PEDAL</b>
0501	3-00183	SILENZIATORE	SILENCER
0503	325019	BALESTRA	LEAF SPRING
0504	425020	CAMMA	CAM
0505	325018	CAVALLOTTO	U-BOLT
0506	425014	BIELLA	TRACE
0508	2-02247	RONDELLA	WASHER
0509	309358	RONDELLA	WASHER
0510	325005	PERNO	PIN
0511	410628	MOLLA	SPRING
0512	325031	PEDALE AUTOCENTR.	PEDAL
0513	325032	PEDALE STALL.	PEDAL
0514	325050	DISTANZIALE	SPACER
0515	5-102714	PEDALE INVERT.	PEDAL
0516	425010	BIELLA	TRACE
0517	425027	LEVA	LEVER
0518	332495	CAVALLOTTO	U-BOLT
0519	5-102739	RUBINETTO DOPPIO	COCK
0521	316199	GHIERA	NUT
0523	433675	REGOLATORE	REGULATOR
0524	524273	SUPPORTO	SUPPORT
0525	325030	PEDALE ALZAPALO	PEDAL
0526	452011	BOCCOLA	BUSHING
0527	317610	TUBO	PIPE
0528	383173	TAPPO	PLUG
0529	2-00211	RONDELLA D.6	WASHER
0530	257137	RUBINETTO SINGOLO	COCK
0531	4-109664	MOLLA	SPRING
0532	2-00025	SEEGER D.12	SEEGER
0533	2-01979	DADO M6	NUT M6
0534	2-00366	VITE M6X40	SCREW
0535	2-01137	DADO M8	NUT
0536	2-00212	RONDELLA D.8	WASHER
0537	2-00411	VITE M6X50	SCREW
0538	2-00312	VITE M6X25	SCREW
0539	2-00155	DADO M6	NUT
0540	2-01272	VITE M2,9X9,5	SCREW

**IMPORTANTE:** per la richiesta dei ricambi far riferimento al codice ricambi (vedi pag. 21).  
**IMPORTANT:** for the request of spare parts please refer to spare parts code (see page 21).  
**IMPORTANT:** pour la demande de pièces de rechange faire référence au code des pièces de rechange (voir pages 21).  
**WICHTIG:** für die Anforderung von Ersatzteilen die Ersatzteilcodes (siehe Seite 21) angeben.  
**IMPORTANTE:** para pedir los repuestos remitirse al código repuestos (ver pag. 21).

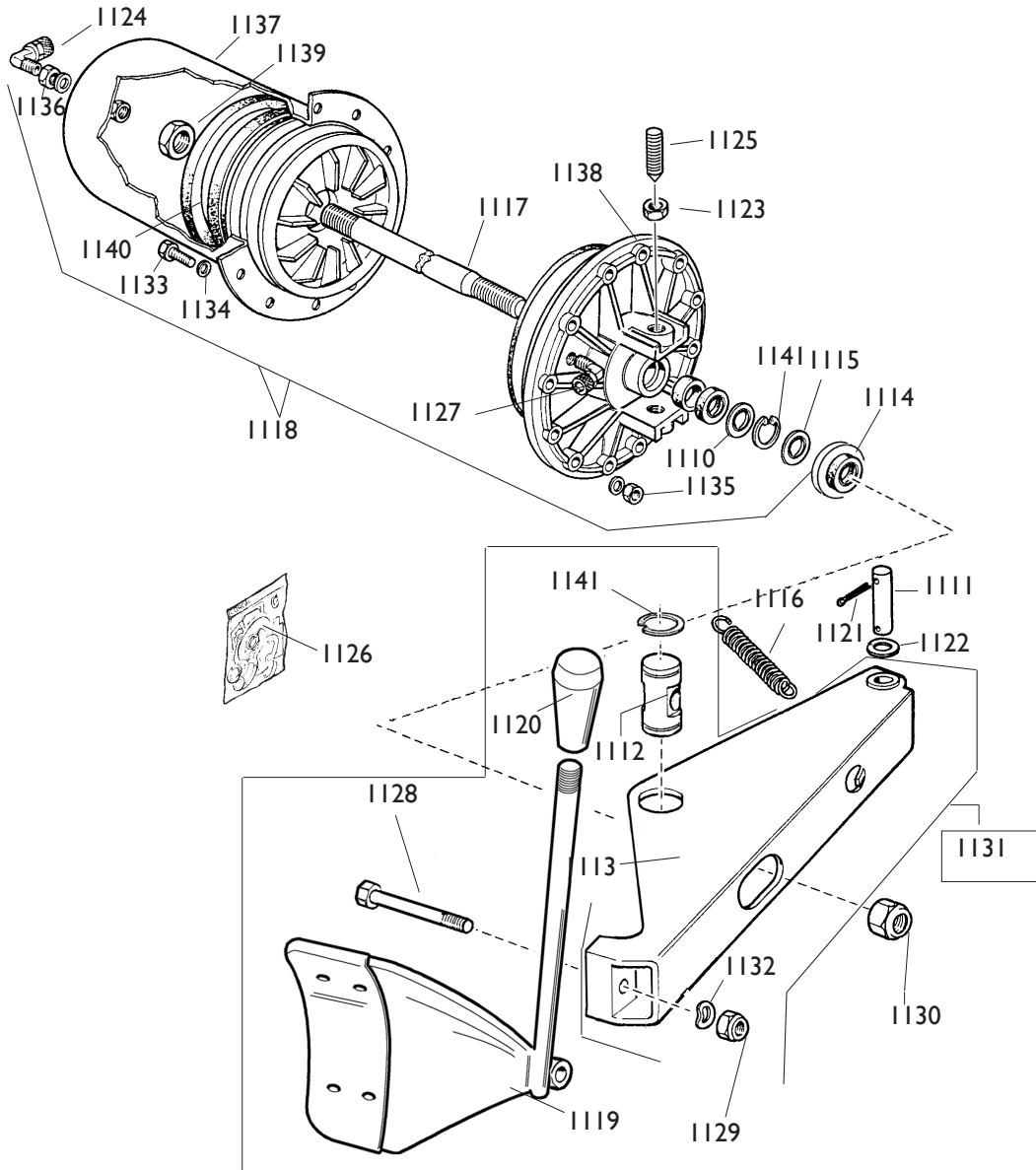



GRUPPO STALLONATORE LATERALE  
LATERAL BEAD-BREAKER UNIT  
GROUPE ETALLONEUR LATERAL  
LATERALE WULSTENTFERNEREINHEIT  
GRUPO DESTALONADOR LATERAL

**AS 933**  
**TAV. E**

1110	325561	RONDELLA	WASHER
1111	323903	PERNO	PIN
1112	33024906	PERNO	PIN
1113	4-103908	BRACCIO STALLONATORE	BEAD-BREAKER ARM
1114	36020245	VITE REG. BRACCIO STALL.	BEAD-BREAKER ARM SCREW
1115	35015286	FINECORSA	STOP SHOCKPROOF PLUG
1116	4-104313	MOLLA	SPRING
1117	4-103920	STELO CILINDRO	CYLINDER STEM
1118	5-101261	CILINDRO STALLONATORE	BEAD-BREAKER CYLINDER
1119	4-102689	PALA STALLONATORE	BEAD-BREAKER BLADE
1120	87221002	IMPUGNATURA	HANDLE
1121	2-00047	COPIGLIA	SPLIT PIN
1122	2-01045	RONDELLA	WASHER
1123	2-00992	DADO	NUT
1124	3-00517	RACCORDO	AIR UNION
1125	431864	GRANO	DOWEL
1126	238212	KIT GUARNIZIONI	SEALS KIT
1127	3-00222	RACCORDO	CONNECTOR
1128	2-02670	VITE	SCREW
1129	2-01106	DADO	NUT
1130	2-01242	DADO	NUT
1131	5-101262	GR.BRACCIO STALL.	BEAD-BREAKER ARM
1132	2-02250	ROSETTA	WASHER
1133	2-00310	VITE M6X20	SCREW
1134	2-00211	RONDELLA D.6	WASHER
1135	436779	DADO M6	NUT
1136	333524	DADO M14	NUT
1137	330190	CANNA CILINDRO	CYLINDER LINER
1138	351905	FONDELLO CILINDRO	CYLINDER BOTTOM
1139	2-00989	DADO	NUT
1140	337848	PISTONE MONOBLOCCO	ENBLOCK PISTON
1141	2-02510	SEGER	SEGER

**IMPORTANTE:** per la richiesta dei ricambi far riferimento al codice ricambi (vedi pag. 21).  
**IMPORTANT:** for the request of spare parts please refer to spare parts code (see page 21).  
**IMPORTANT:** pour la demande de pièces de rechange faire référence au code des pièces de rechange (voir pages 21).  
**WICHTIG:** für die Anforderung von Ersatzteilen die Ersatzteilcodes (siehe Seite 21) angeben.  
**IMPORTANTE:** para pedir los repuestos remitirse al código repuestos (ver pag. 21).

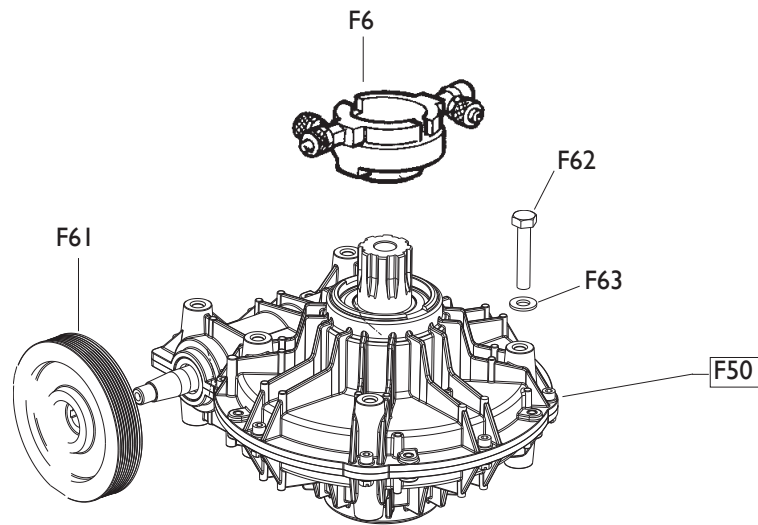



MOTORIDUTTORE  
REDUCTION MOTOR  
MOTORE-DUCTEUR  
GETRIEBEMOTOR  
MOTORIDUCTOR

**AS 933**  
**TAV. F**

F50	5-102647	RIDUTTORE	GEAR BOX
F61	314344	PULEGGIA D.130	PULLEY
F62	2-01046	VITE M10X55	SCREW
F63	2-00213	RONDELLA D.10	WASHER
F6	228389	RACCORDO GIREVOLE NO TI	CONNECTOR



MORSA PNEUMATICA  
 PNEUMATIC CHUCK  
 ATEU PNEUMATIQUE  
 PNEUMATISCHER SCHRAUBSTOCK  
 GARRAS NEUMATICA

AS 933  
 TAV. G

9650

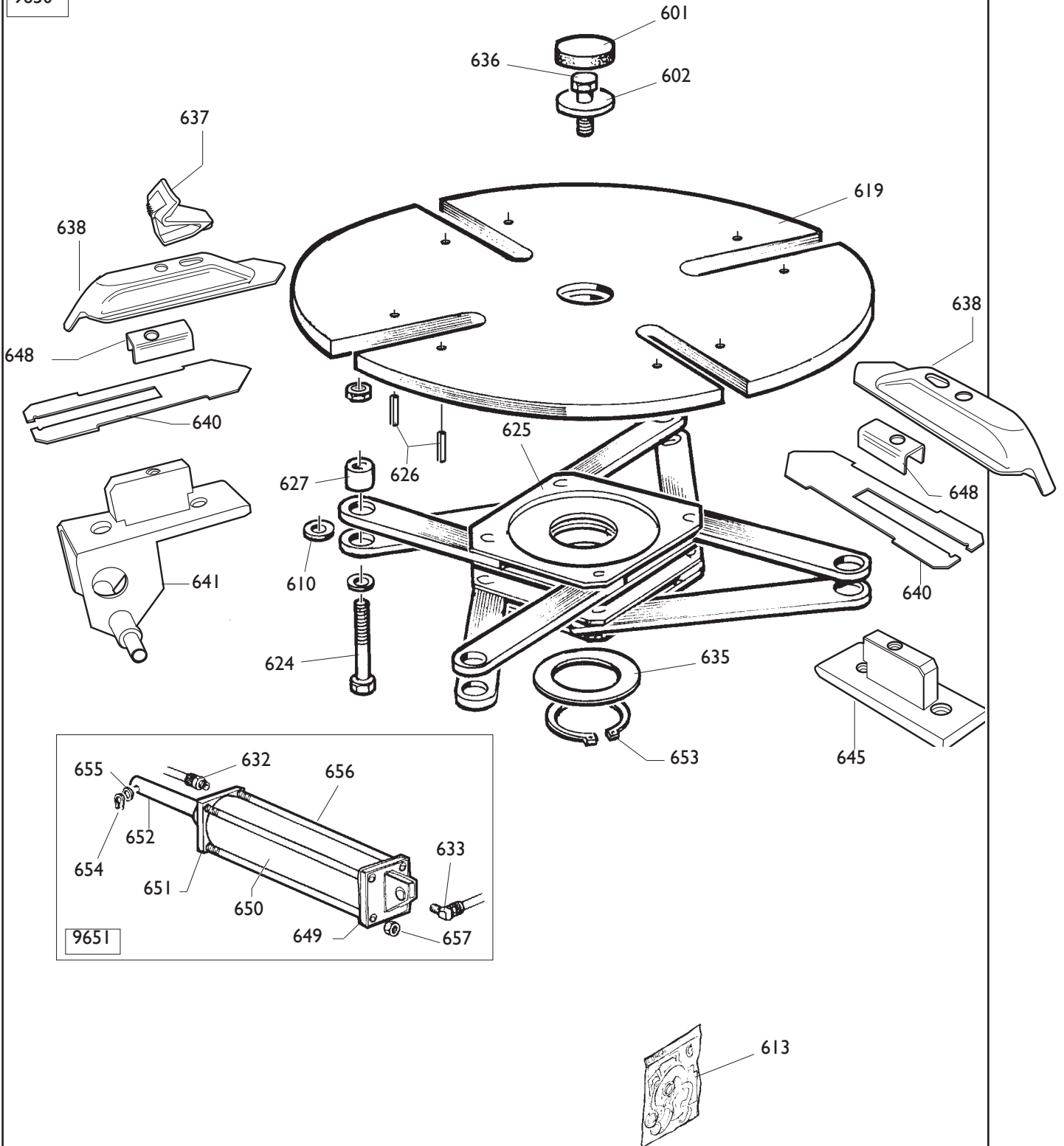





MORSA PNEUMATICA  
PNEUMATIC CHUCK  
ATEU PNEUMATIQUE  
PNEUMATISCHER SCHRAUBSTOCK  
GARRAS NEUMATICA

AS 933  
TAV. G

9650	5-100408	AUTOCENTRANTE 10"-20"	10"-20" TURNTABLE
0601	426514	TAPPO	PLUG
0602	323363	RONDELLA	WASHER
0613	238548	KIT GUARNIZIONI	SEALS KIT
0610	437964	RONDELLA	WASHER
0619	253758	PIATTO	PLATE
0624	2-03295	VITE	SCREW
0625	4-101651	FLANGIA	FLANGE
0626	2-01059	SPINA	PLUG
0627	337965	BOCCOLA	BUSHING
0635	455082	RONDELLA	WASHER
0636	2-01216	VITE	SCREW
0637	3008225	CUNEO	JAW
0638	4-101872	SCORREVOLE	SLIDER
0640	4-101151	SLITTA	SLIDE
0641	4-101130	SUPPORTO SCORR. TRAINANTE	SLIDER
0645	4-101122	SUPPORTO SCORR. TRAINATO	SLIDER
0648	4-101812	LAMIERA	SLIDER
0653	2-01283	SEEGER D.65	SEEGER D.65
0654	2-00025	SEEGER D.12	SEEGER D.12
0655	2-00214	RONDELLA.12	WASHER

9651	253784	CILINDRO DESTRO	CYLINDER RIGHT
9651	253783	CILINDRO SINISTRO	CYLINDER LEFT
0632	3-02045	RACCORDO DRITTO	FITTING
0633	3-02044	RACCORDO A 90°	90° FITTING
0649	4-115948	FLANGIA POST.	FLANGE
0650	4-115951	CAMICIA	LINER
0651	5-105111	FLANGIA ANT.	FLANGE
0652	4-115950	STELO	ROD
0656	4-115949	TIRANTE	TIE-ROD
0657	2-01137	DADO M8	NUT

9750

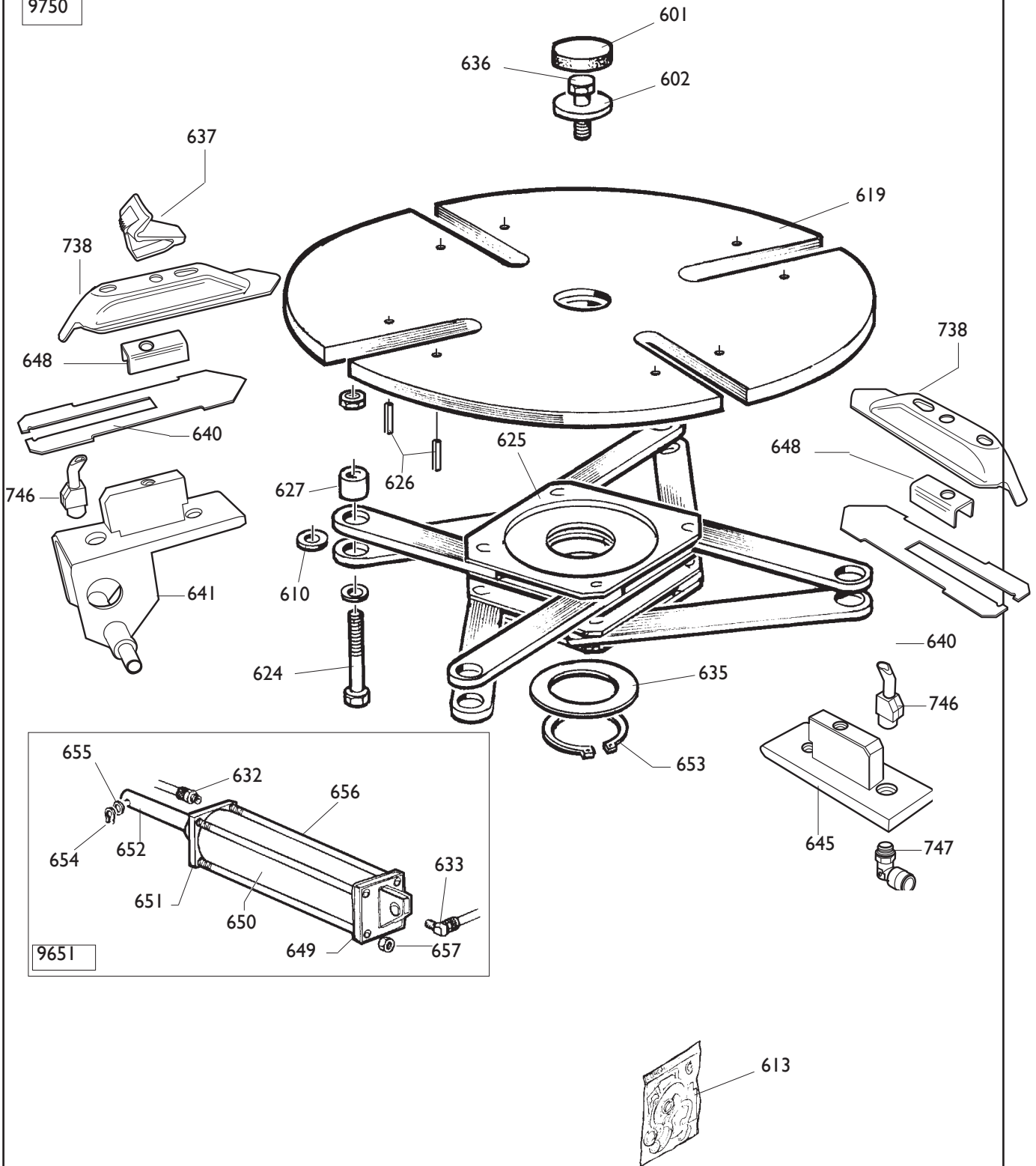



MORSA PNEUMATICA T.I  
PNEUMATIC CHUCK T.I  
ATEU PNEUMATIQUE T.I  
PNEUMATISCHER SCHRAUBSTOCK T.I  
GARRAS NEUMATICA T.I

**AS 933**  
**TAV. H**

9750	5-100385	AUTOCENTRANTE 10"-20" TI	10"-20" TI TURNTABLE
0601	426514	TAPPO	PLUG
0602	323363	RONDELLA	WASHER
0613	238548	KIT GUARNIZIONI	SEALS KIT
0610	437964	RONDELLA	WASHER
0619	253758	PIATTO	PLATE
0624	2-03295	VITE	SCREW
0625	4-101651	FLANGIA	FLANGE
0626	2-01059	SPINA	PLUG
0627	337965	BOCCOLA	BUSHING
0635	455082	RONDELLA	WASHER
0636	2-01216	VITE	SCREW
0637	3008225	CUNEO	JAW
0640	4-101151	SLITTA	SLIDE
0641	4-101130	SUPPORTO SCORR.TRAINANTE	SLIDER
0645	4-101122	SUPPORTO SCORR.TRAINATO	SLIDER
0648	4-101812	LAMIERA	SLIDER
0738	4-101871	SCORREVOLE	SLIDER
0746	4-101918	UGELLO	NOZZLE
0747	3-00517	RACCORDO	FITTING
0653	2-01283	SEEGER D.65	SEEGER D.65
0654	2-00025	SEEGER D.12	SEEGER D.12
0655	2-00214	RONDELLA.12	WASHER

9651	253784	CILINDRO DESTRO	CYLINDER RIGHT
9651	253783	CILINDRO SINISTRO	CYLINDER LEFT
0632	3-02045	RACCORDO DRITTO	FITTING
0633	3-02044	RACCORDO A 90°	90° FITTING
0649	4-115948	FLANGIA POST.	FLANGE
0650	4-115951	CAMICIA	LINER
0651	5-105111	FLANGIA ANT.	FLANGE
0652	4-115950	STELO	ROD
0656	4-115949	TIRANTE	TIE-ROD
0657	2-01137	DADO M8	NUT

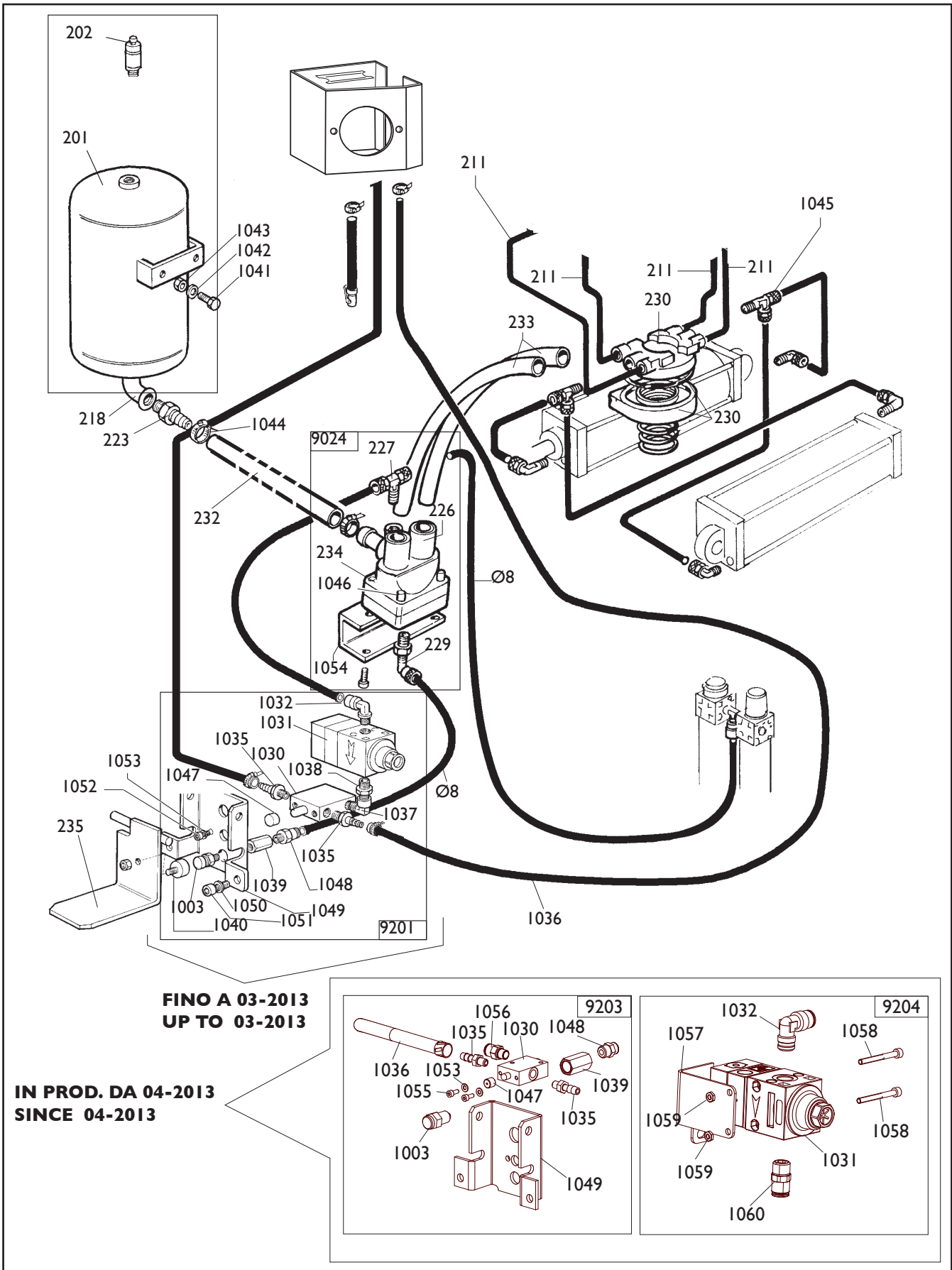



IMPIANTO PNEUMATICO T.I.  
 PNEUMATIC SYSTEM T.I.  
 INSTALLATION PNEUMATIQUE T.I.  
 PNEUMATISCHE ANLAGE T.I.  
 INSTALACION NEUMATICA T.I.

**AS 933**  
**TAV. I**

Ø 6	1-01684	TUBO	PIPE
Ø 8	1-01683	TUBO	PIPE
0201	240968	SERBATOIO	TANK
0202	3-00356	VALVOLA	VALVE
0211	1-04223	TUBO	PIPE
0218	438995	RACCORDO	CONNECTOR
0223	337704	RACCORDO	CONNECTOR
0235	252625	PEDALE	PEDAL

9024	242290	VALVOLA DI SPARO CPL	VALVE FIRING CPL
0226	3-00403	CARTUCCIA	CARTRIDGE
0227	3-00287	RACCORDO	CONNECTOR
0229	3-00051	RACCORDO	CONNECTOR
0234	243020	VALVOLA DI SPARO	VALVE FIRING
1046	2-94066	VITE M6X40	SCREW
1054	342286	STAFFA	BRACKET

0230	241841	RACCORDO GIREVOLE TI	CONNECTOR
0232	342288	TUBO	PIPE
0233	4-103544	TUBO	PIPE
1041	2-00373	VITE M8X20	SCREW
1042	2-00212	RONDELA D.8	WASHER
1043	2-00112	DADO M8	NUT
1044	403751	FASCETTA	FASTEN
1045	3-00117	RACCORDO	CONNECTOR

9201	252568	GRUPPO GONFIAGGIO	GROUP INFLATION
<b>9203</b>	<b>5-105676</b>	<b>GRUPPO GONFIAGGIO</b>	<b>GROUP INFLATION</b>
<b>9204</b>	<b>5-105674</b>	<b>VALVOLA GONF. + STAFFA</b>	<b>VALVE WITH PLATE</b>
1003	235463	VALVOLA SGONFIAGGIO	VALVE
1030	3-00365	VALVOLA	VALVE
<b>1031</b>	<b>3-00389</b>	<b>VALVOLA GONFIAGGIO</b>	<b>VALVE</b>
1032	3-00221	RACCORDO	CONNECTOR
1035	3-00004	INNESTO	CLUTCH
1036	352614	TUBO aria L.1900mm	PIPE
1037	3-00138	RACCORDO	CONNECTION
1038	3-00135	NIPPLO	CONNECTION
1039	338576	DISTANZIALE	SPACE
1040	452624	ANTIVIBRANTE	ANTISHOCK
1047	352619	CAPPELOTTO	BOLT
1048	3-00460	RACCORDO	CONNECTOR
1049	352968	SUPPORTO	SUPPORT
1050	2-00212	RONDELLA D.8	WASHER
1051	2-00320	VITE M8	SCREW
1052	2-00295	VITE M4X8	SCREW
1053	2-00209	RONDELLA D.4	WASHER
<b>1055</b>	<b>2-00289</b>	<b>VITE M4X10</b>	<b>SCREW</b>
<b>1056</b>	<b>3-00464</b>	<b>RACCORDO D.8</b>	<b>CONNECTOR D.8</b>
<b>1057</b>	<b>4-117416</b>	<b>SUPPORTO</b>	<b>SUPPORT</b>
<b>1058</b>	<b>2-00851</b>	<b>VITE M4X40</b>	<b>SCREW</b>
<b>1059</b>	<b>2-02804</b>	<b>DADO M4</b>	<b>NUT</b>
<b>1060</b>	<b>3-00478</b>	<b>RACCORDO D.8</b>	<b>CONNECTOR D.8</b>

**IMPORTANTE:** per la richiesta dei ricambi far riferimento al codice ricambi (vedi pag. 23).  
**IMPORTANT:** for the request of spare parts please refer to spare parts code (see page 23).  
**IMPORTANT:** pour la demande de pièces de rechange faire référence au code des pièces de rechange (voir pages 23).  
**WICHTIG:** für die Anforderung von Ersatzteilen die Ersatzteilcodes (siehe Seite 23) angeben.  
**IMPORTANTE:** para pedir los repuestos remitirse al código repuestos (ver pag. 23).

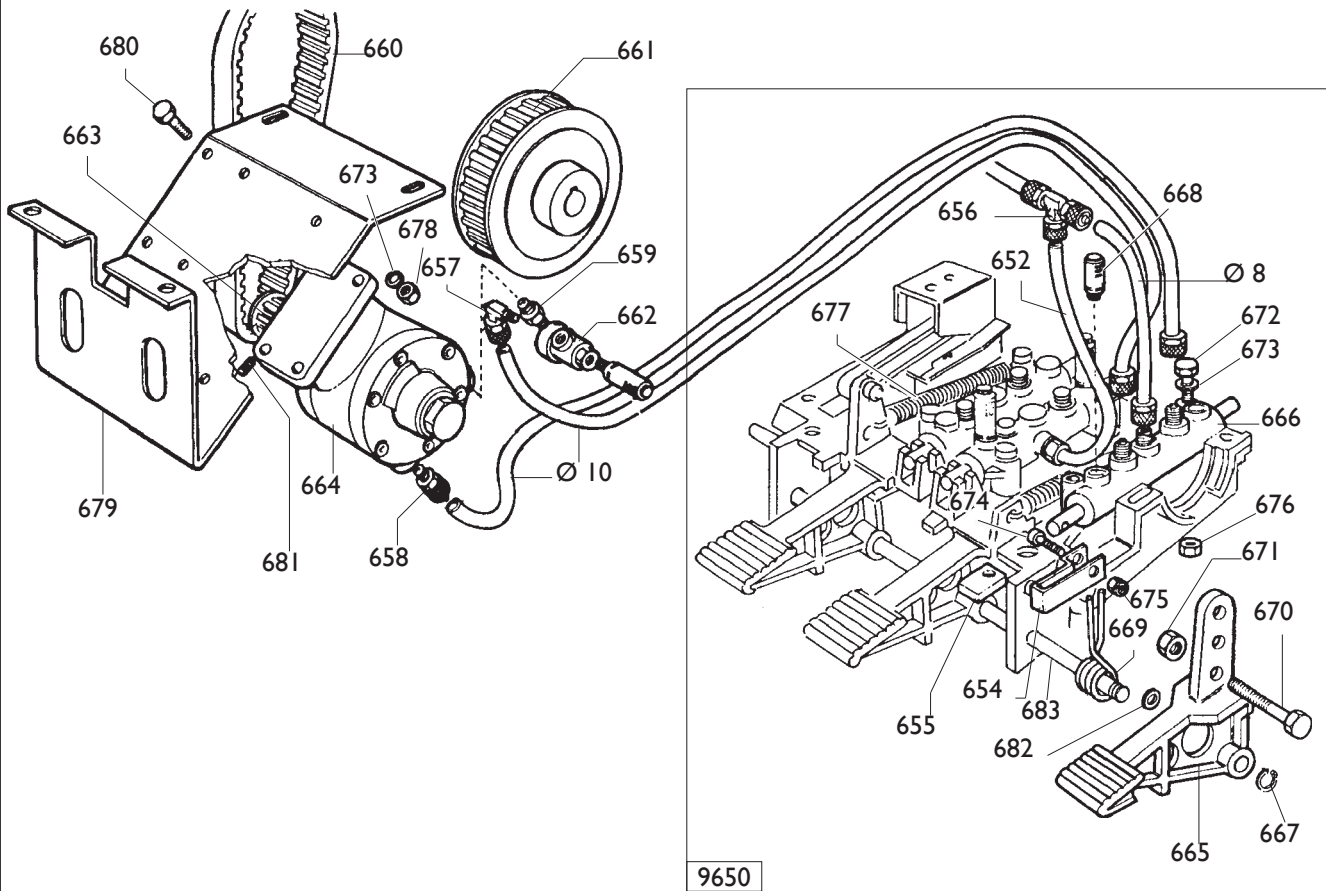



PEDALIERA PNEUMATICA  
PNEUMATIC PEDAL UNIT  
GROUPE PEDALES PNEUMATIQUE  
PNEUMATISCHER PEDALEINHEIT  
GRUPO PEDALES NEUMATICO

AS 933  
TAV. L

9650	233677	PEDALIERA PNEUM.	CONTROL PEDAL
Ø 8	1-01683	TUBO	PIPE
0652	322705	TUBO	PIPE
0654	331381	BIELLA	TRACE
0655	329058	PIASTRINA	PLATE
0656	3-00112	RACCORDO	CONNECTOR
0665	252030	PEDALE INVERTITORE	PEDAL
0666	5-102740	RUBINETTO SINGOLO	COCK
0667	2-00025	SEEGER	SEEGER
0668	3-00183	SILENZIATORE 1/8	CONNECTOR
0669	4-109664	MOLLA	SPRING
0670	2-00366	VITE M6X40	SCREW
0671	2-01979	DADO M6	NUT
0672	2-00411	VITE M6X50	SCREW
0673	2-00211	RONDELLA D.6	WASHER
0674	2-00291	VITE M4X20	SCREW
0675	2-01018	DADO M4	NUT
0676	2-01137	DADO M8	NUT
0677	410628	MOLLA	SPRING
0678	422288	DADO	NUT
0679	334768	CULLA	SUPPORT
Ø 10	1-01875	TUBO	PIPE
0657	3-00109	RACCORDO	CONNECTOR
0658	3-00040	RACCORDO	CONNECTOR
0659	3-00141	NIPPLO	CONNECTION
0660	3-00585	CINGHIA	BELT
0661	319073	PULEGGIA CONDOTTA	PULLEY
0661	314344	PULEGGIA D.130	PULLEY
0662	3-00316	VALVOLA	VALVE
0663	319076	PULEGGIA	PULLEY
0664	319135	MOTORE	MOTOR
0680	2-00363	VITE M6X25	SCREW
0681	2-00801	VITE M6X6	SCREW
0682	452011	BOCCOLA	BUSH
0683	325005	PERNO	PIN

**IMPORTANTE:** per la richiesta dei ricambi far riferimento al codice ricambi (vedi pag. 24).  
**IMPORTANT:** for the request of spare parts please refer to spare parts code (see page 24).  
**IMPORTANT:** pour la demande de pièces de rechange faire référence au code des pièces de rechange (voir pages 24).  
**WICHTIG:** für die Anforderung von Ersatzteilen die Ersatzteilcodes (siehe Seite 24) angeben.  
**IMPORTANTE:** para pedir los repuestos remitirse al código repuestos (ver pag. 24).

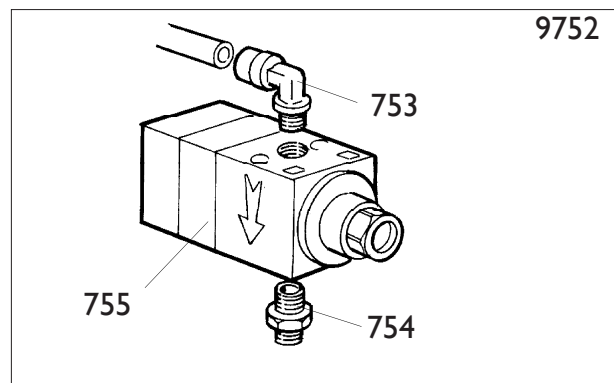
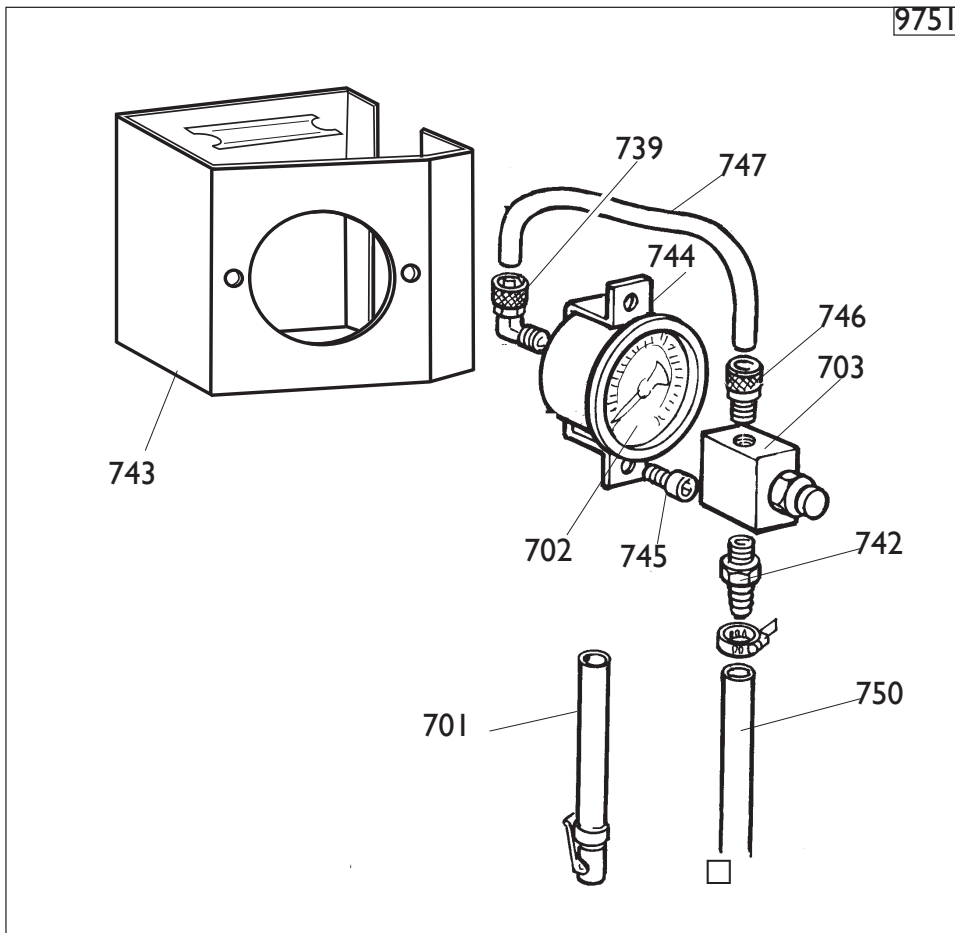





GRUPPO MANOMETRO + LIMITATORE  
MANOMETER+LIMITER GROUP  
GROUPE MANOMETER + LIMITEUR  
MANOMETER + BEGRENZUNG GRUPPE  
GRUPO MANOMETRO + LIMITADOR

**AS 933**  
**TAV. M**

9751	5-100696	SCATOLA - BAR/PSI	BOX - BAR/PSI
9751	5-105062	SCATOLA - BAR	BOX - BAR
9751	5-104698	SCATOLA - KPA	BOX - KPA
0701	262971	TUBO GONFIAGGIO	PIPE
0702	3-00490	MANOMETRO BAR - PSI	GAUGE BAR - PSI
0702	3-00486	MANOMETRO BAR	GAUGE BAR
0702	3-00493	MANOMETRO KPA	GAUGE KPA
0703	235463	VALVOLA	VALVE
0739	3-00103	RACCORDO	CONNECTOR
0742	3-00007	INNESTO	CLUTCH
0743	4-102371	SCATOLA MANOMETRO	BOX
0744	353537	SUPPORTO MANOMETRO	SUPPORT
0745	2-71485	VITE M3,9X13	SCREW
0746	3-00460	RACCORDO	CONNECTOR
0747	329245	TUBO D.6 L.280 mm	PIPE
0750	354410	TUBO aria L.3150 mm	PIPE

9752	252558	VALVOLA	VALVE
0753	3-00055	RACCORDO	CONNECTOR
0754	352557	RACCORDO	CONNECTOR
0755	3-00389	VALVOLA	VALVE

**IMPORTANTE:** per la richiesta dei ricambi far riferimento al codice ricambi (vedi pag. 24).  
**IMPORTANT:** for the request of spare parts please refer to spare parts code (see page 24).  
**IMPORTANT:** pour la demande de pièces de rechange faire référence au code des pièces de rechange (voir pages 24).  
**WICHTIG:** für die Anforderung von Ersatzteilen die Ersatzteilcodes (siehe Seite 24) angeben.  
**IMPORTANTE:** para pedir los repuestos remitirse al código repuestos (ver pag. 24).

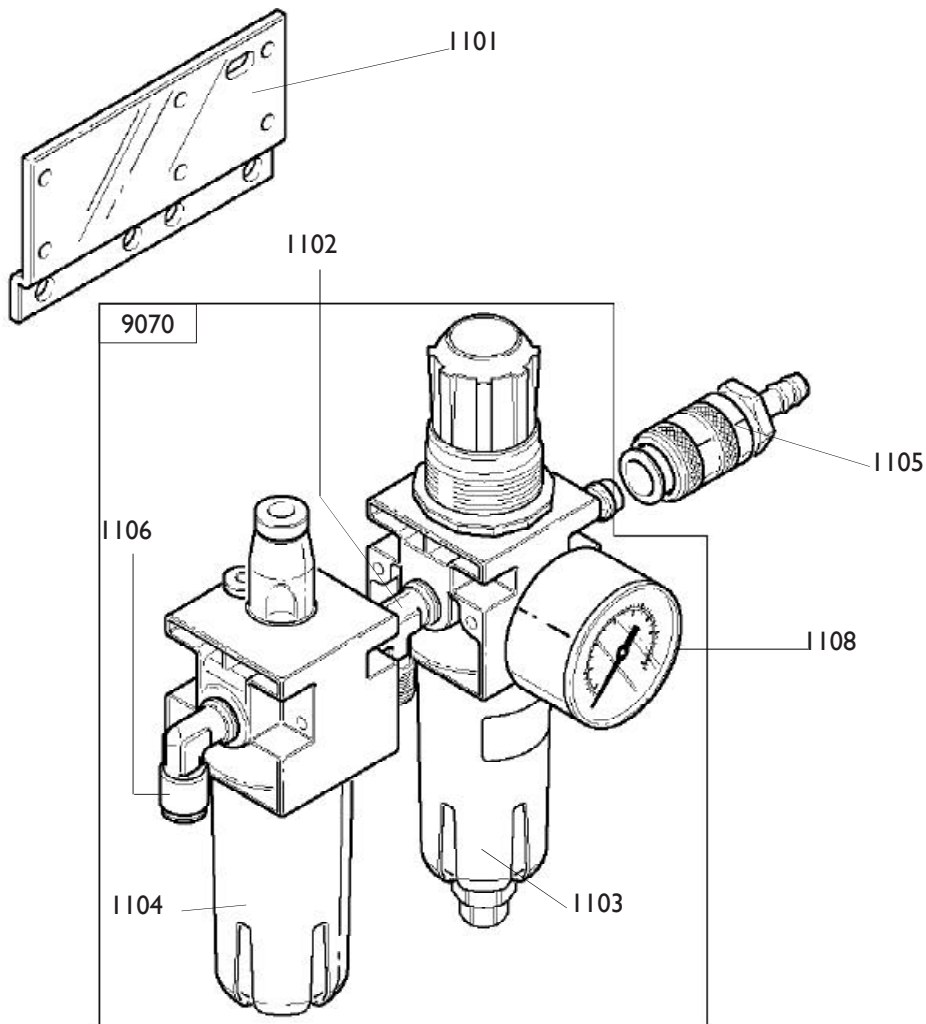



GRUPPO FRL  
FRL GROUP  
GROUPE FILTRE LUBRIFICATEUR  
SCHIEMFILTER GRUPPE  
GRUPO FRL FILTRO-LUBRIFICADOR

**AS 933**  
**TAV. N**

9070	456522	FILTRO	FILTER
1102	3-00001	RACCORDO	CONNECTOR
1103	457512	BICCHIERE	BOWL
1104	457511	BICCHIERE	BOWL
1106	3-00221	RACCORDO	CONNECTOR
1108	3-00488	MANOMETRO BAR-PSI	PRESSURE GAUGE BAR PSI
1108	3-00494	MANOMETRO KPA	PRESSURE GAUGE KPA
1101	4-102273	STAFFA	BRACKET
1105	3-00257	GIUNTO	COUPLING

**IMPORTANTE:** per la richiesta dei ricambi far riferimento al codice ricambi (vedi pag. 25).  
**IMPORTANT:** for the request of spare parts please refer to spare parts code (see page 25).  
**IMPORTANT:** pour la demande de pièces de rechange faire référence au code des pièces de rechange (voir pages 25).  
**WICHTIG:** für die Anforderung von Ersatzteilen die Ersatzteilcodes (siehe Seite 25) angeben.  
**IMPORTANTE:** para pedir los repuestos remitirse al código repuestos (ver pag. 25).

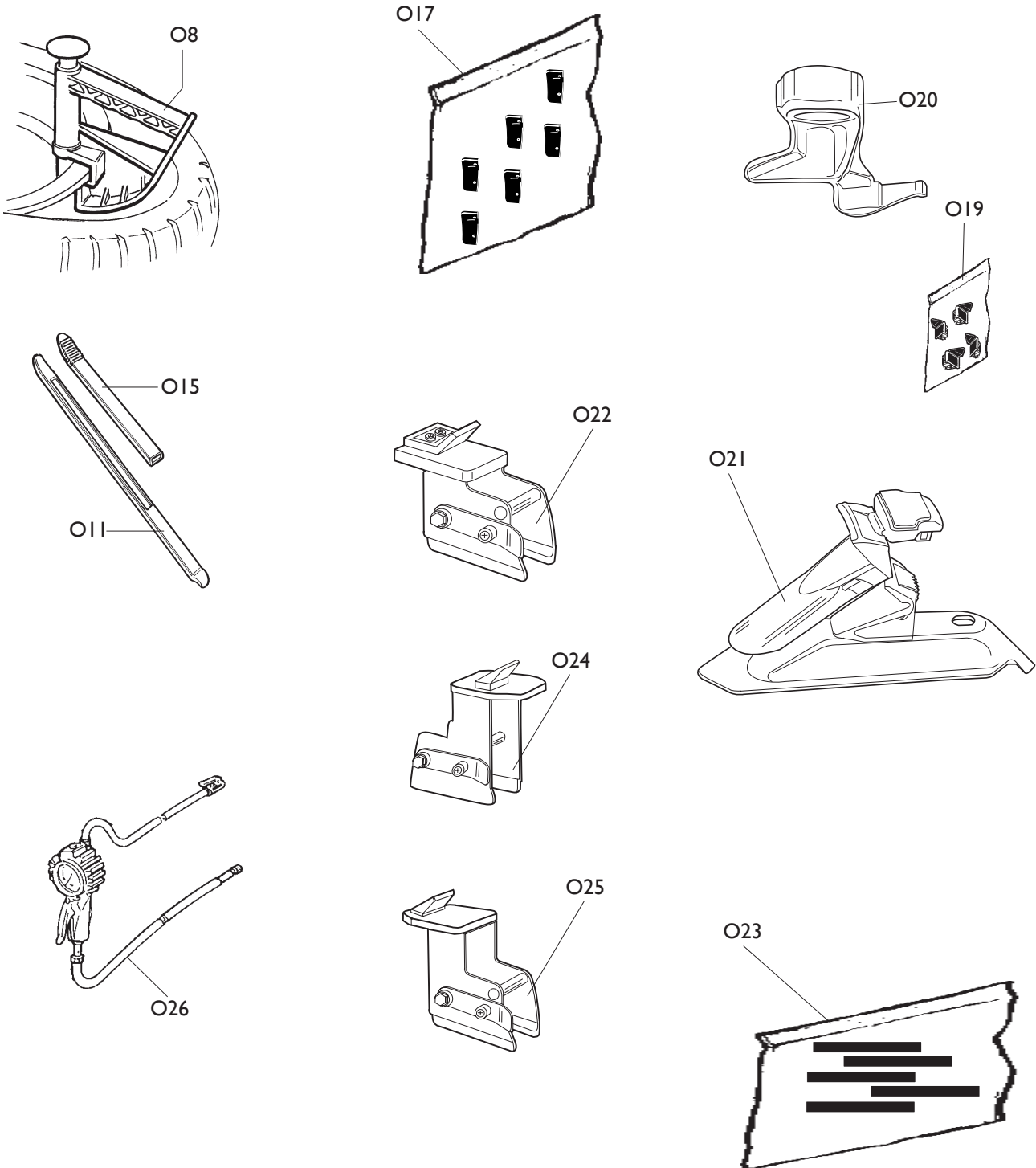



ACCESSORI  
ACCESSORIES  
ACCESSOIRES  
ZUBEHÖRTEILE  
ACCESORIOS

AS 933  
TAV. O

O8	801435685	PINZA	PLIERS
O11	4-108275	LEVA	LEVER
O15	801246241	KIT 6 PROTEZ.LEVA	SHIELD
O17	801258383	KIT 6 PROTEZ.PALETTA	SHIELD
O19	801254341	KIT 10 INSERT	SHIELD
O20	801252083	KIT TORRETTA 8"	HEAD KIT 8"
O21	2200573	KIT 4 PROTEZ.GRIFFA	INSERTS
O22	8-11100069	KIT 4 ADATTATORI 8	ADAPTOR
O23	801258898	KIT 5 PASTIGLIE	INSERT
O24	8-11100068	KIT n° 4 ADATTATORI 4"	4" ADAPTORS KIT
O25	8-11100070	KIT n° 4 ADATT.MOTO 14"-23"	MOTORCYCLE ADAPTORS KIT
O26	3-00427	PISTOLA BAR/PSI	INFLATING GAUGE BAR-PSI
O26	3-00323	PISTOLA BAR	INFLATING GAUGE BAR

**IMPORTANTE:** per la richiesta dei ricambi far riferimento al codice ricambi (vedi pag. 25).  
**IMPORTANT:** for the request of spare parts please refer to spare parts code (see page 25).  
**IMPORTANT:** pour la demande de pièces de rechange faire référence au code des pièces de rechange (voir pages 25).  
**WICHTIG:** für die Anforderung von Ersatzteilen die Ersatzteilcodes (siehe Seite 25) angeben.  
**IMPORTANTE:** para pedir los repuestos remitirse al código repuestos (ver pag. 25).

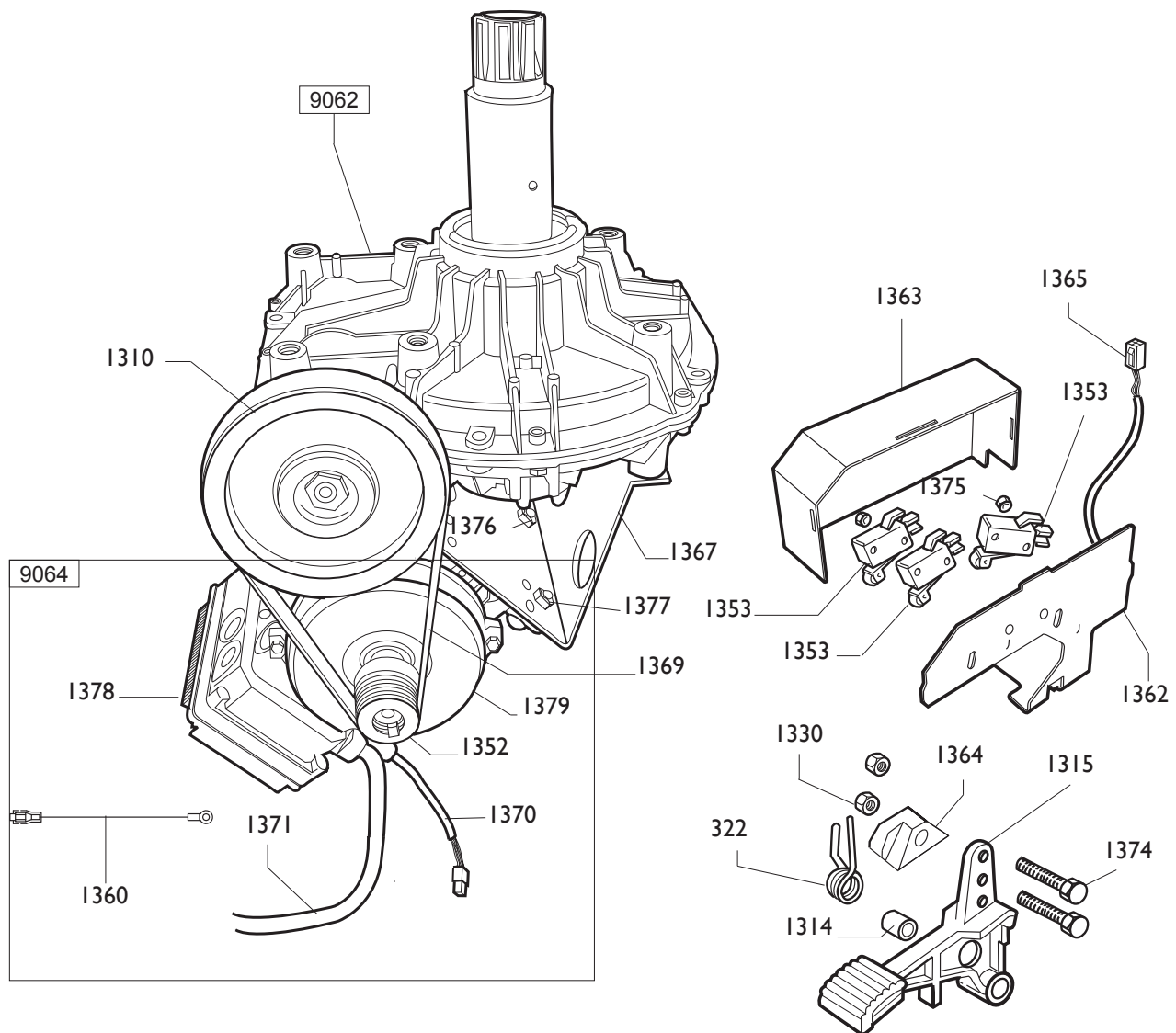



GRUPPO DV  
 DOUBLE SPEED GROUP  
 GROUPE DOUBLE VITESSE  
 SATZ DOPPELGESCHWINDIGKEIT  
 GRUPO DOS VELOCIDADES

AS 933  
 TAV. P

MOTORE+INV 2 CONDENSATORI			MOTOR+REV.
9064	5-104986	200-230V I <sub>PH</sub>	200-230V I <sub>PH</sub>
1352	4-102397	PULEGGIA	PULLEY
1360	4-101659	CAVO TERRA	CABLE
1370	4-109895	CAVO COMANDI 230V	CABLE
1371	4-111586	CAVO RETE	CABLE
1378	4-115396	SCHEDA ELETTR. 230V	P.C.BOARD
1379	4-113412	MOTOINV. (NO SK)200-230/1/50-60HZ	MOTOINVERTER 230V

MOTORE+INV			MOTOR+REV..
9064	5-104995	115V I <sub>PH</sub>	115V I <sub>PH</sub>
1352	4-102397	PULEGGIA	PULLEY
1360	4-101659	CAVO TERRA	CABLE
1371	4-111586	CAVO RETE	CABLE
1378	4-113414	SCHEDA ELETTR. 115V	P.C.BOARD
1370	4-109895	CAVO COMANDI 115V	CABLE
1379	4-113412	MOTOINV. (NO SK) 115V	MOTOINVERTER 115V

9062	5-102648	RIDUTTORE	GEAR BOX
1310	339870	PULEGGIA	PULLEY

0322	4-109664	MOLLA	SPRING
1314	325050	DISTANZIALE	SPACER
1315	5-102714	PEDALE	PEDAL
1330	346008	BOCCOLA	BUSHING
1353	440874	MICROINTERUTORE	MICROSWITCH
1362	4-102401	SUPPORTO MICRO	SUPPORT
1363	4-102402	COPERCHIO	CASING
1364	461535	SUPPORTO MICRO	SUPPORT
1365	4-101693	CAVO COMANDI PEDALIERA	CABLE
1367	4-109965	CULLA MOTORE 230/115V	SUPPORT
1369	3-00573	CINGHIA	BELT
1374	2-00441	VITE M6X50	SCREW
1375	2-00124	DADO M4	NUT
1376	421349	DADO M8	NUT
1377	2-00375	VITE M8X30	SCREW

UTB. cod. 4-104323E - 04/2013.



**MONDOLFO FERRO S.p.a.**  
Viale dell'industria, 20 - 61037 MONDOLFO (PU) Italy  
[info@mondolfoferro.it](mailto:info@mondolfoferro.it)  
[www.mondolfoferro.it](http://www.mondolfoferro.it)