

LISTA COMPONENTI
LIST OF COMPONENTS
LISTE DE COMPOSANTS
ERSATZTEILLISTE
LISTA DE LOS COMPONENTES

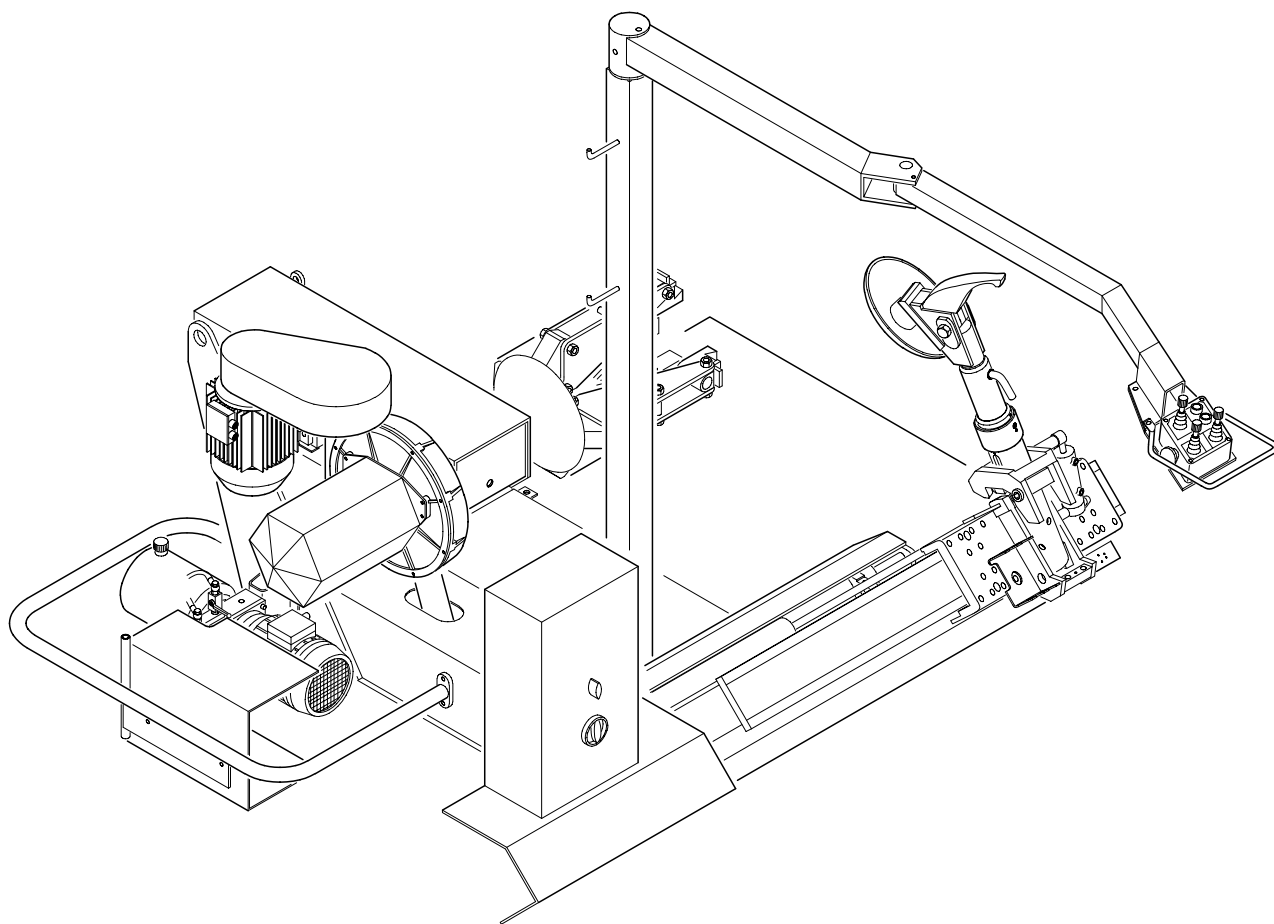

TBE 156 S
TBE 156 DL
TBE 156 N

ISTRUZIONI PER LA RICHIESTA DEI RICAMBI

- 1) Consultando le tavole di seguito riportate, individuare esattamente il n. del particolare desiderato (Ex. Tav. A n. A10).
- 2) Dalla tabella ricambi, trovare il corrispondente codice (Ex. 80050100)
- 3) Nella richiesta specificare esattamente :
Il modello ed il n. di matricola della macchina.
Il codice ricambio (n. 8 cifre) del particolare desiderato.
Ex. TBE 156 matr. 100, cod. 80050100.

INSTRUCTIONS FOR REQUESTING SPARE PARTS

- 1) Consulting the following tables, single out the exact n. of spare parts requested (Eg. Table A n. A10).
- 2) Find the corresponding spare parts code from the spare parts table (E. 80050100)
- 3) In the request specify exactly:
The model and serial n. of the machine.
The spare parts code (8 figures) of the requested spare part.
Eg. TBE 156 serial n. 100, code 80050100.

INSTRUCTIONS POUR LA DEMANDE DE PIECES DE RECHANGE

- 1) En consultant les tables ci-après, individualiser exactement le n. du détail désiré (Ex. Table A n. A10).
- 2) De la table des pièces de rechange, trouver le code correspondant (Ex. 80050100)
- 3) Dans la demande spécifier exactement:
Le modèle et le n. de matricule de la machine.
Le code pièce de rechange (n. 8 chiffres) du détail désiré.
Ex. TBE 156 matr. 100, code 80050100.

ANWEISUNG FÜR DIE ERSATZTEILANFORDERUNG

- 1) Bestimmen Sie genau anhand der nach stehend angeführten Übersichtstafeln die Nummer des gewünschten Teils (z.B. Tav. A Nr. A10).
- 2) Aus der Ersatzteiltafel den entsprechen den Code aufnoieren Z.B. 80050100
- 3) Bezeichnen Sie in der Anforderung klar und präzise:
Das Model und die Maschinennummer.
Den Ersatzteilcode (8 Ziffern) des gewünschten Teils.
Z.B. TBE 156 matr. 100, cod. 80050100.

INSTRUCCIONES PARA EL PEDIDO DE REPUESTOS

- 1) Consultando las tablas detalladas a continuación, identificar exactamente el n° de las piezas que se desean pedir (Ej. Tav. A n. A10).
- 2) Partiendo de la tabla, encontrar el código correspondiente (ej.: 80050100)
- 3) En el pedido especificar exactamente:
El modelo y el n° de la matricola de la máquina.
El código del repuesto (n° 8 cifras) de la pieza deseada.
Ej. TBE 156 matr. 100, cod 80050100.

IMPORTANTE: per la richiesta dei ricambi far riferimento al codice ricambi (vedi pag. 22).

IMPORTANT: for the request of spare parts please refer to spare parts code (see page 22).

IMPORTANT: pour la demande de pièces de rechange faire référence au code des pièces de rechange (voir pages 22).

WICHTIG: für die Anforderung von Ersatzteilen die Ersatzteilcodes (siehe Seite 22) angeben.

IMPORTANTE: para pedir los repuestos remitirse al código repuestos (ver pag. 22).

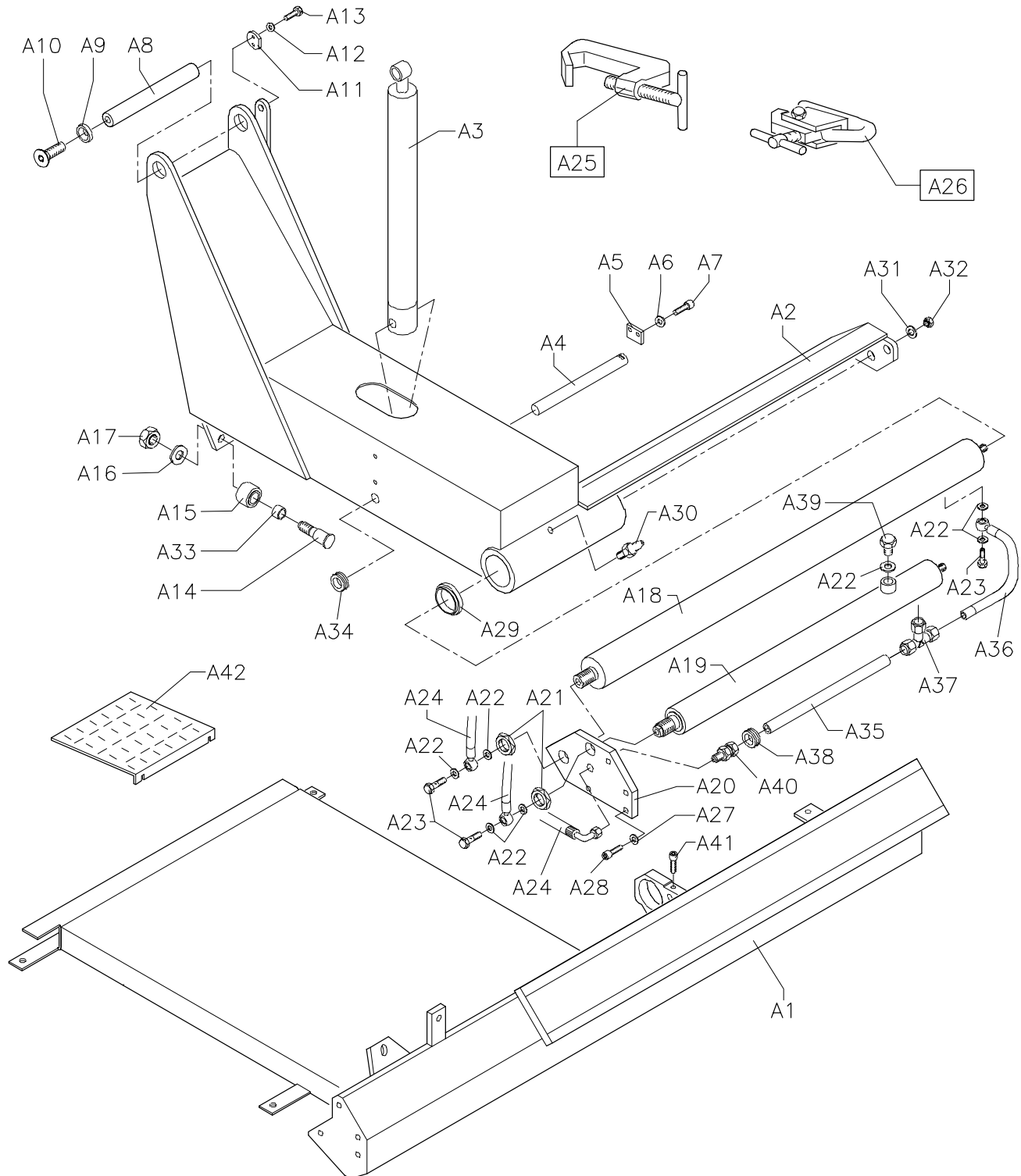

IMPORTANTE: per la richiesta dei ricambi far riferimento al codice ricambi (vedi pag. 23).

IMPORTANT: for the request of spare parts please refer to spare parts code (see page 23).

IMPORTANT: pour la demande de pièces de rechange faire référence au code des pièces de rechange (voir pages 23).

WICHTIG: für die Anforderung von Ersatzteilen die Ersatzteilcodes (siehe Seite 23) angeben.

IMPORTANTE: para pedir los repuestos remitirse al código repuestos (ver pag. 23).

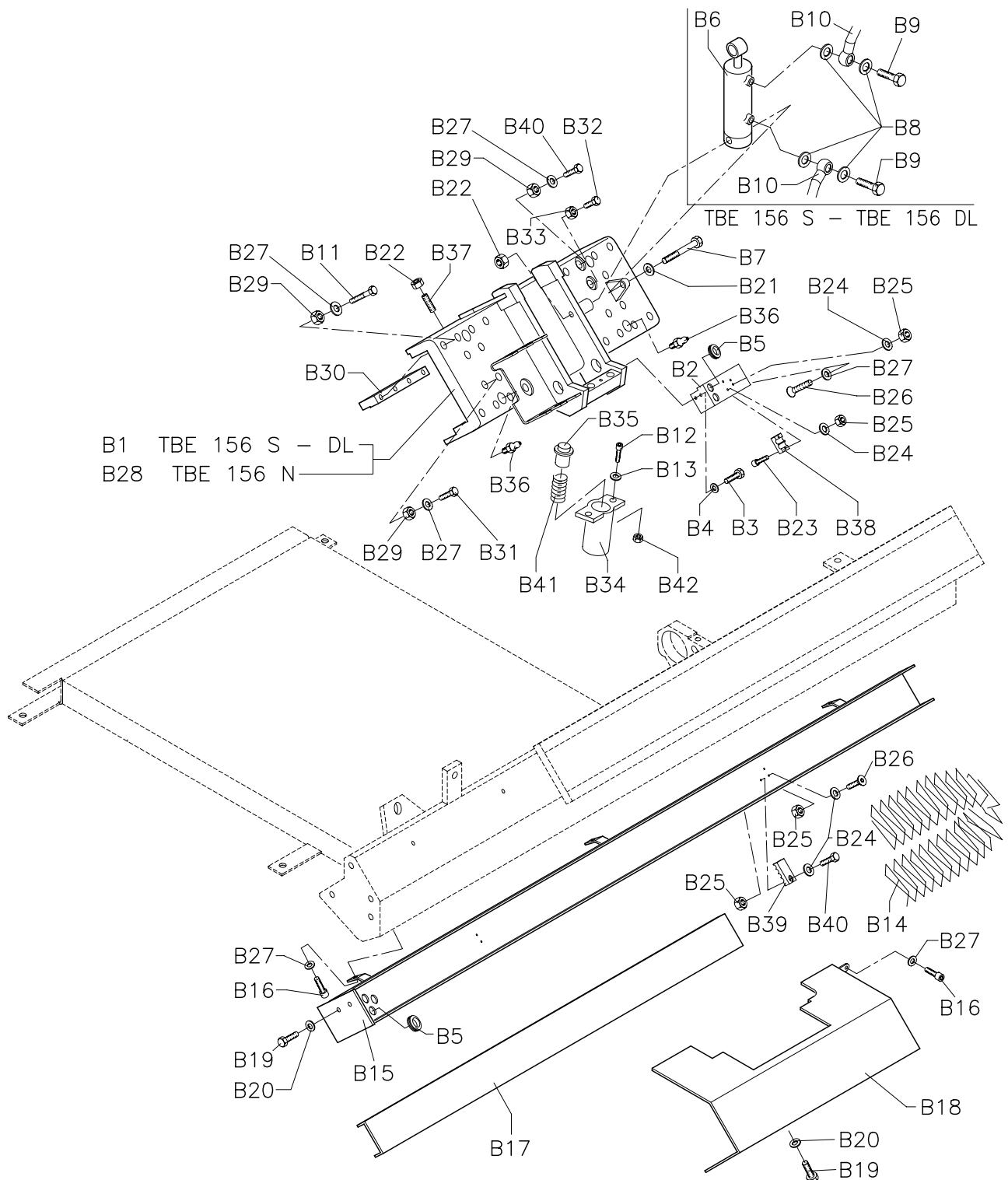

IMPORTANTE: per la richiesta dei ricambi far riferimento al codice ricambi (vedi pag. 24).
IMPORTANT: for the request of spare parts please refer to spare parts code (see page 24).
IMPORTANT: pour la demande de pièces de rechange faire référence au code des pièces de rechange (voir pages 24).
WICHTIG: für die Anforderung von Ersatzteilen die Ersatzteilcodes (siehe Seite 24) angeben.
IMPORTANTE: para pedir los repuestos remitirse al código repuestos (ver pag. 24).

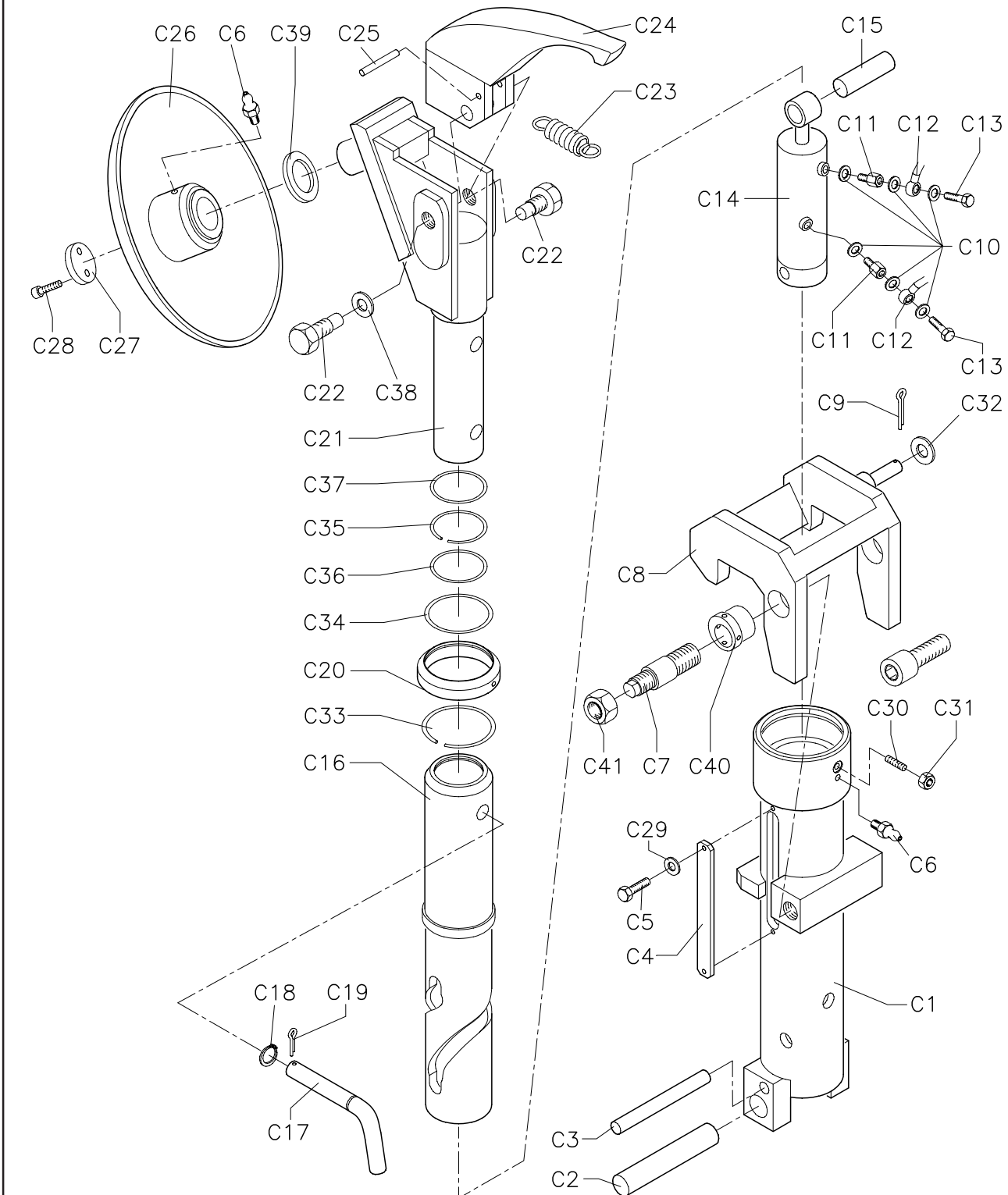

IMPORTANTE: per la richiesta dei ricambi far riferimento al codice ricambi (vedi pag. 25).
IMPORTANT: for the request of spare parts please refer to spare parts code (see page 25).
IMPORTANT: pour la demande de pièces de rechange faire référence au code des pièces de rechange (voir pages 25).
WICHTIG: für die Anforderung von Ersatzteilen die Ersatzteilcodes (siehe Seite 25) angeben.
IMPORTANTE: para pedir los repuestos remitirse al código repuestos (ver pag. 25).

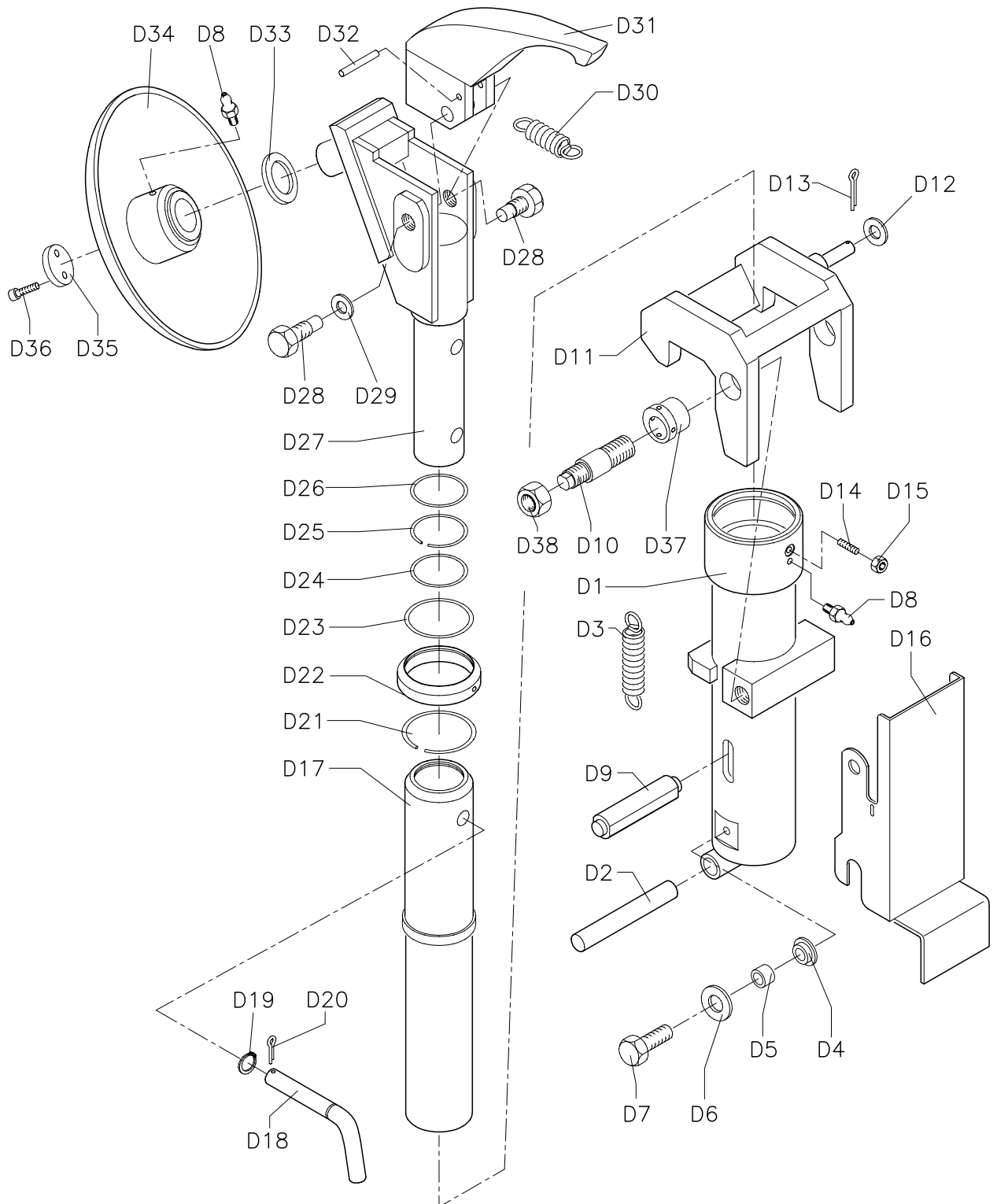

IMPORTANTE: per la richiesta dei ricambi far riferimento al codice ricambi (vedi pag. 26).
IMPORTANT: for the request of spare parts please refer to spare parts code (see page 26).
IMPORTANT: pour la demande de pièces de rechange faire référence au code des pièces de rechange (voir pages 26).
WICHTIG: für die Anforderung von Ersatzteilen die Ersatzteilcodes (siehe Seite 26) angeben.
IMPORTANTE: para pedir los repuestos remitirse al código repuestos (ver pag. 26).

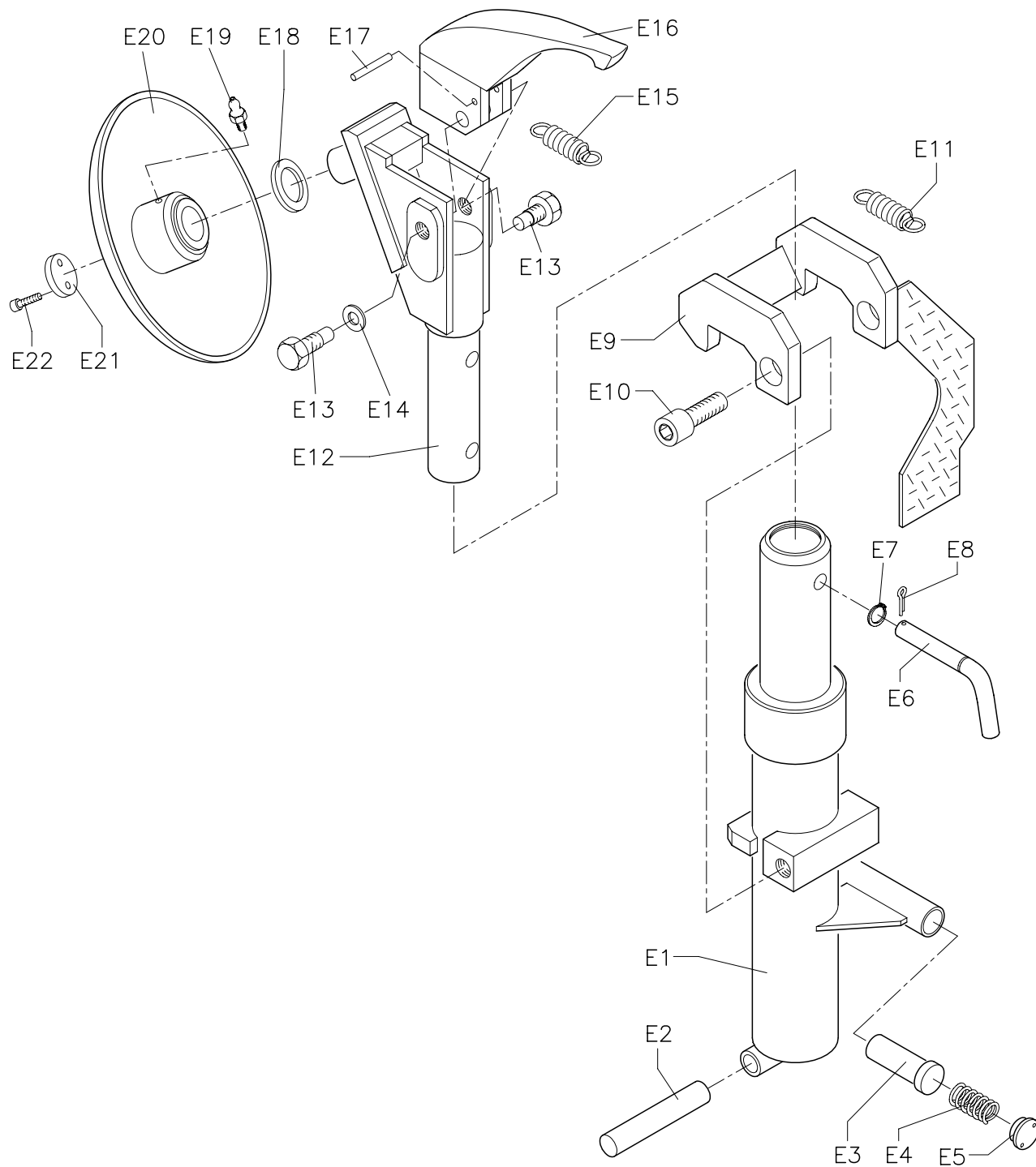

IMPORTANTE: per la richiesta dei ricambi far riferimento al codice ricambi (vedi pag. 26).
IMPORTANT: for the request of spare parts please refer to spare parts code (see page 26).
IMPORTANT: pour la demande de pièces de rechange faire référence au code des pièces de rechange (voir pages 26).
WICHTIG: für die Anforderung von Ersatzteilen die Ersatzteilcodes (siehe Seite 26) angeben.
IMPORTANTE: para pedir los repuestos remitirse al código repuestos (ver pag. 26).

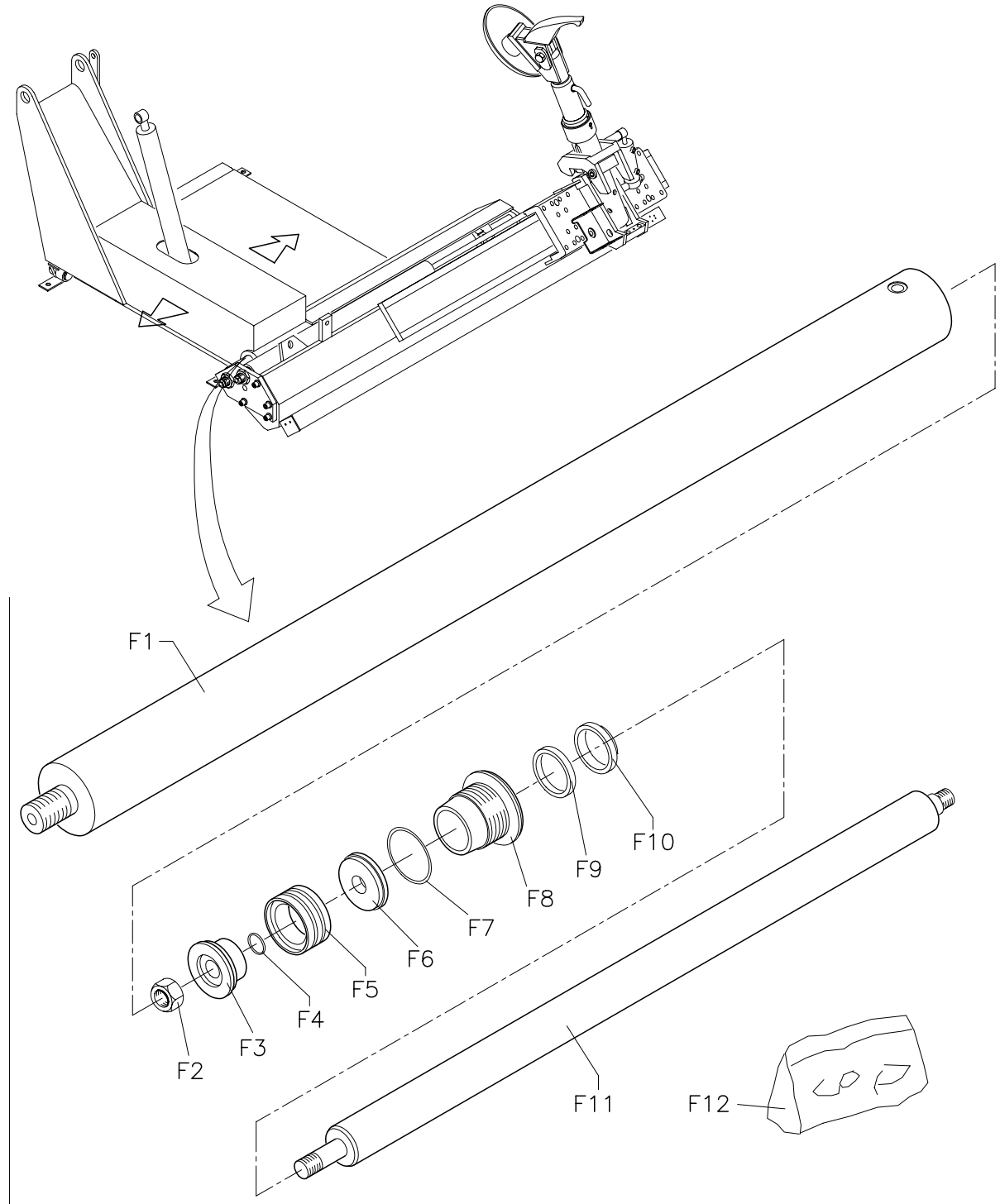

F13

IMPORTANTE: per la richiesta dei ricambi far riferimento al codice ricambi (vedi pag. 27).
IMPORTANT: for the request of spare parts please refer to spare parts code (see page 27).
IMPORTANT: pour la demande de pièces de rechange faire référence au code des pièces de rechange (voir pages 27).
WICHTIG: für die Anforderung von Ersatzteilen die Ersatzteilcodes (siehe Seite 27) angeben.
IMPORTANTE: para pedir los repuestos remitirse al código repuestos (ver pag. 27).

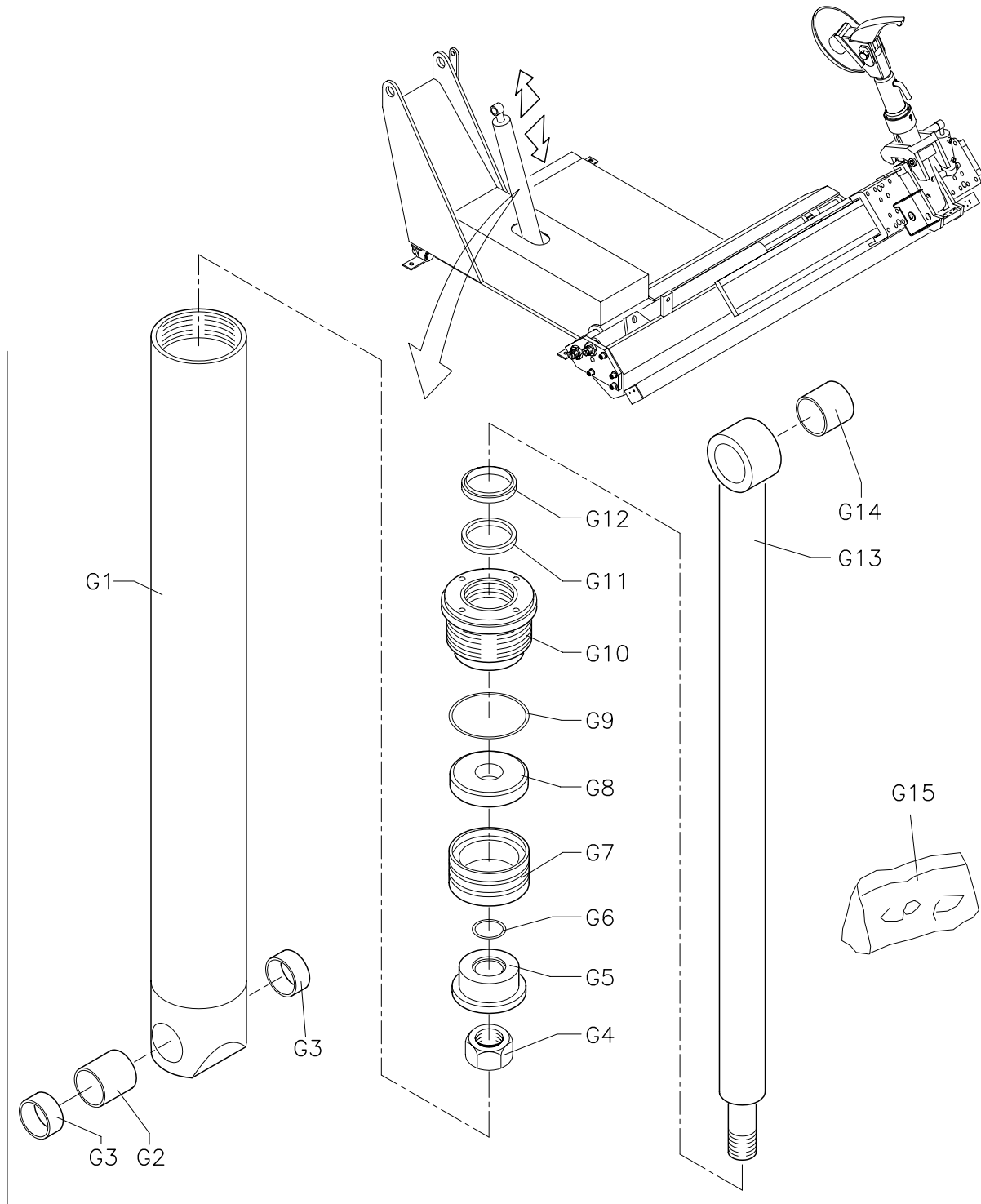

G16

IMPORTANTE: per la richiesta dei ricambi far riferimento al codice ricambi (vedi pag. 27).
IMPORTANT: for the request of spare parts please refer to spare parts code (see page 27).
IMPORTANT: pour la demande de pièces de rechange faire référence au code des pièces de rechange (voir pages 27).
WICHTIG: für die Anforderung von Ersatzteilen die Ersatzteilcodes (siehe Seite 27) angeben.
IMPORTANTE: para pedir los repuestos remitirse al código repuestos (ver pag. 27).

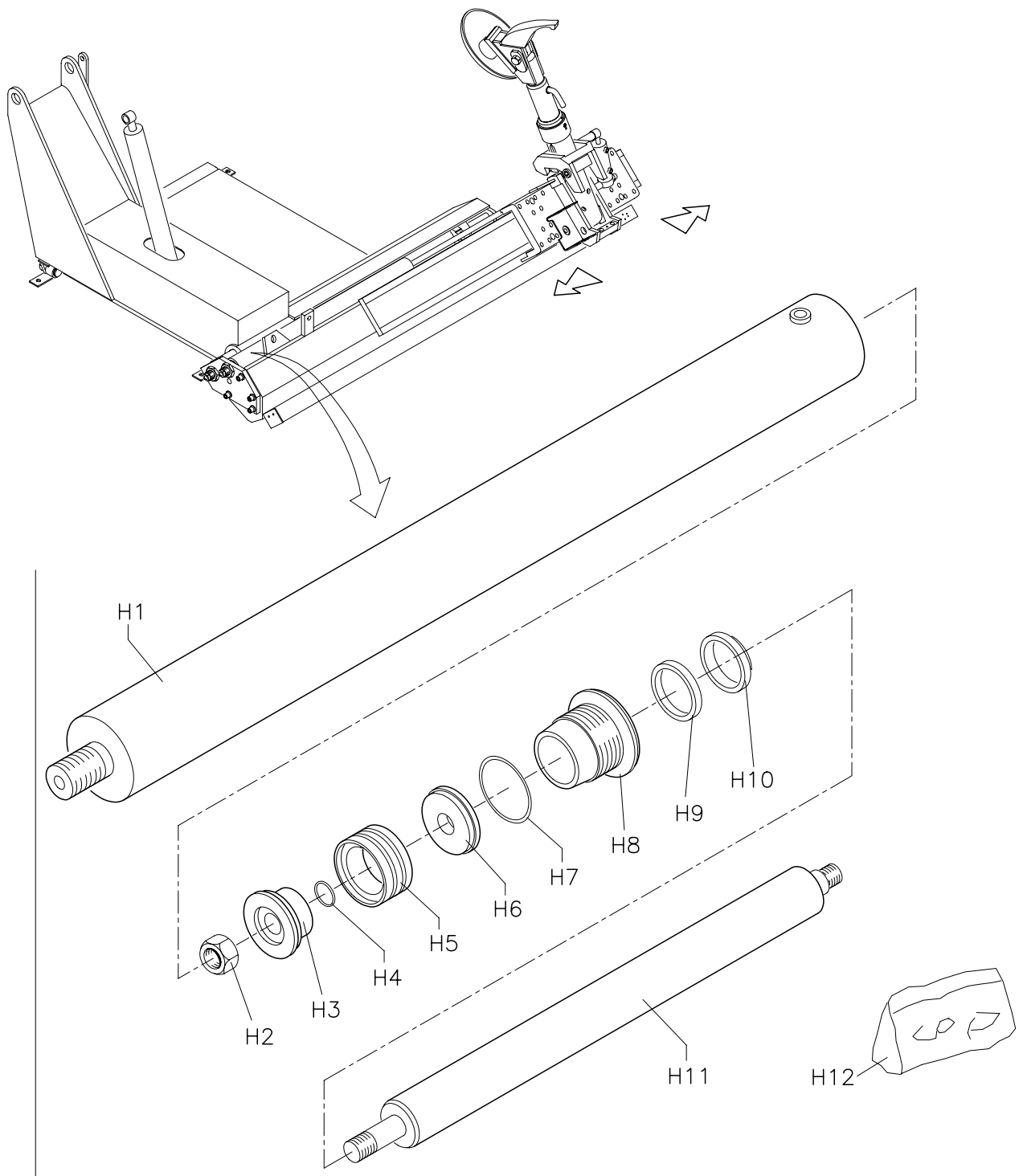

H13

IMPORTANTE: per la richiesta dei ricambi far riferimento al codice ricambi (vedi pag. 28).
IMPORTANT: for the request of spare parts please refer to spare parts code (see page 28).
IMPORTANT: pour la demande de pièces de rechange faire référence au code des pièces de rechange (voir pages 28).
WICHTIG: für die Anforderung von Ersatzteilen die Ersatzteilcodes (siehe Seite 28) angeben.
IMPORTANTE: para pedir los repuestos remitirse al código repuestos (ver pag. 28).

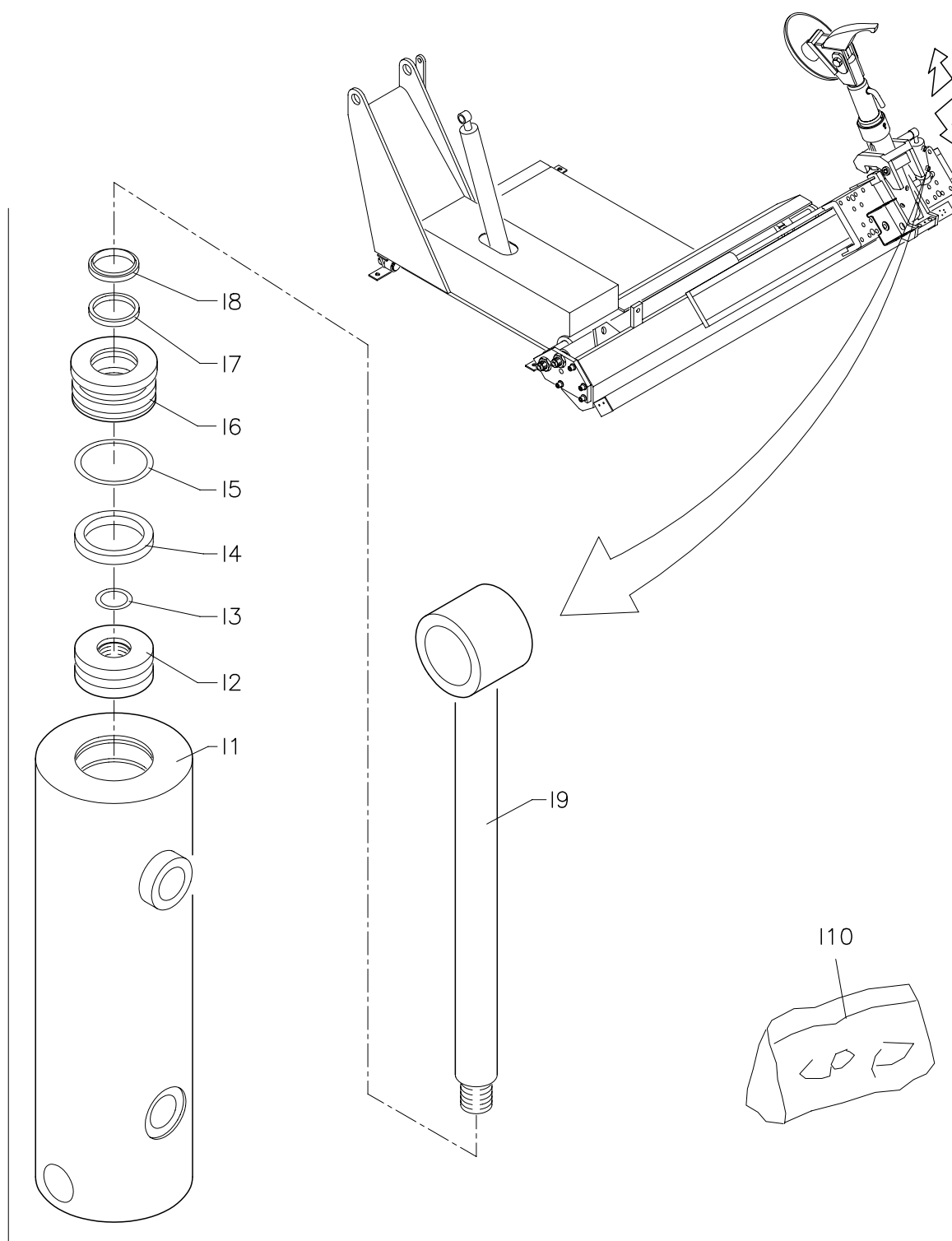

I11

IMPORTANTE: per la richiesta dei ricambi far riferimento al codice ricambi (vedi pag. 28).
IMPORTANT: for the request of spare parts please refer to spare parts code (see page 28).
IMPORTANT: pour la demande de pièces de rechange faire référence au code des pièces de rechange (voir pages 28).
WICHTIG: für die Anforderung von Ersatzteilen die Ersatzteilcodes (siehe Seite 28) angeben.
IMPORTANTE: para pedir los repuestos remitirse al código repuestos (ver pag. 28).

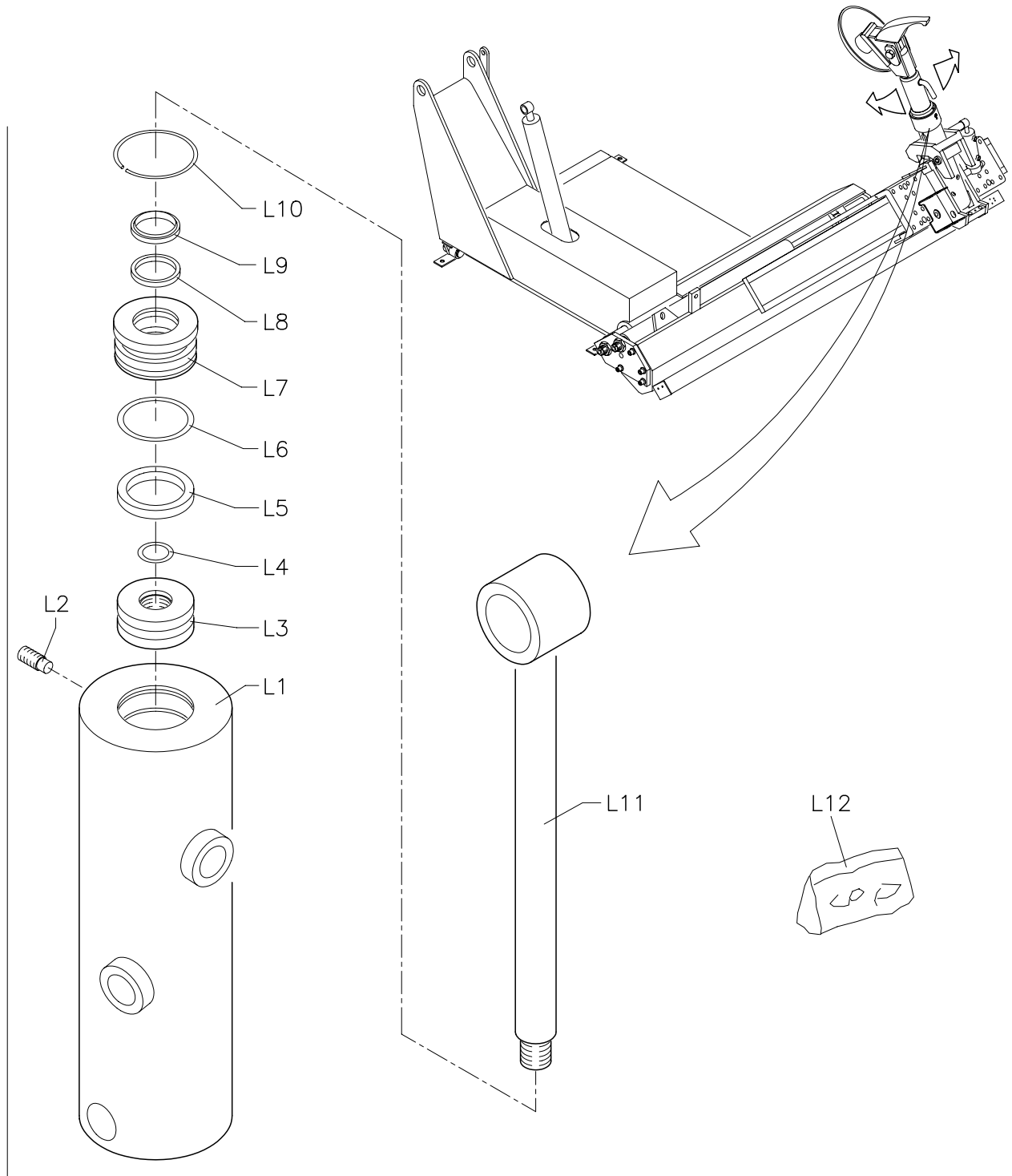

L13



BRACCIO COMANDI
CONTROL ARM
BRAS DE COMMANDES
STEUERARM
BRAZO DE MANDOS

TBE 156 S
TBE 156 DL
TBE 156 N
TAV. M

IMPORTANTE: per la richiesta dei ricambi far riferimento al codice ricambi (vedi pag. 29).
IMPORTANT: for the request of spare parts please refer to spare parts code (see page 29).
IMPORTANT: pour la demande de pièces de rechange faire référence au code des pièces de rechange (voir pages 29).
WICHTIG: für die Anforderung von Ersatzteilen die Ersatzteilcodes (siehe Seite 29) angeben.
IMPORTANTE: para pedir los repuestos remitirse al código repuestos (ver pag. 29).

TBE 156 S

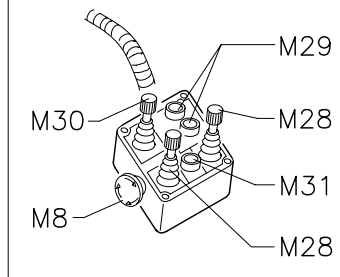

TBE 156 DL

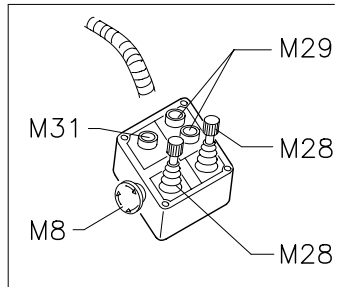

TBE 156 N

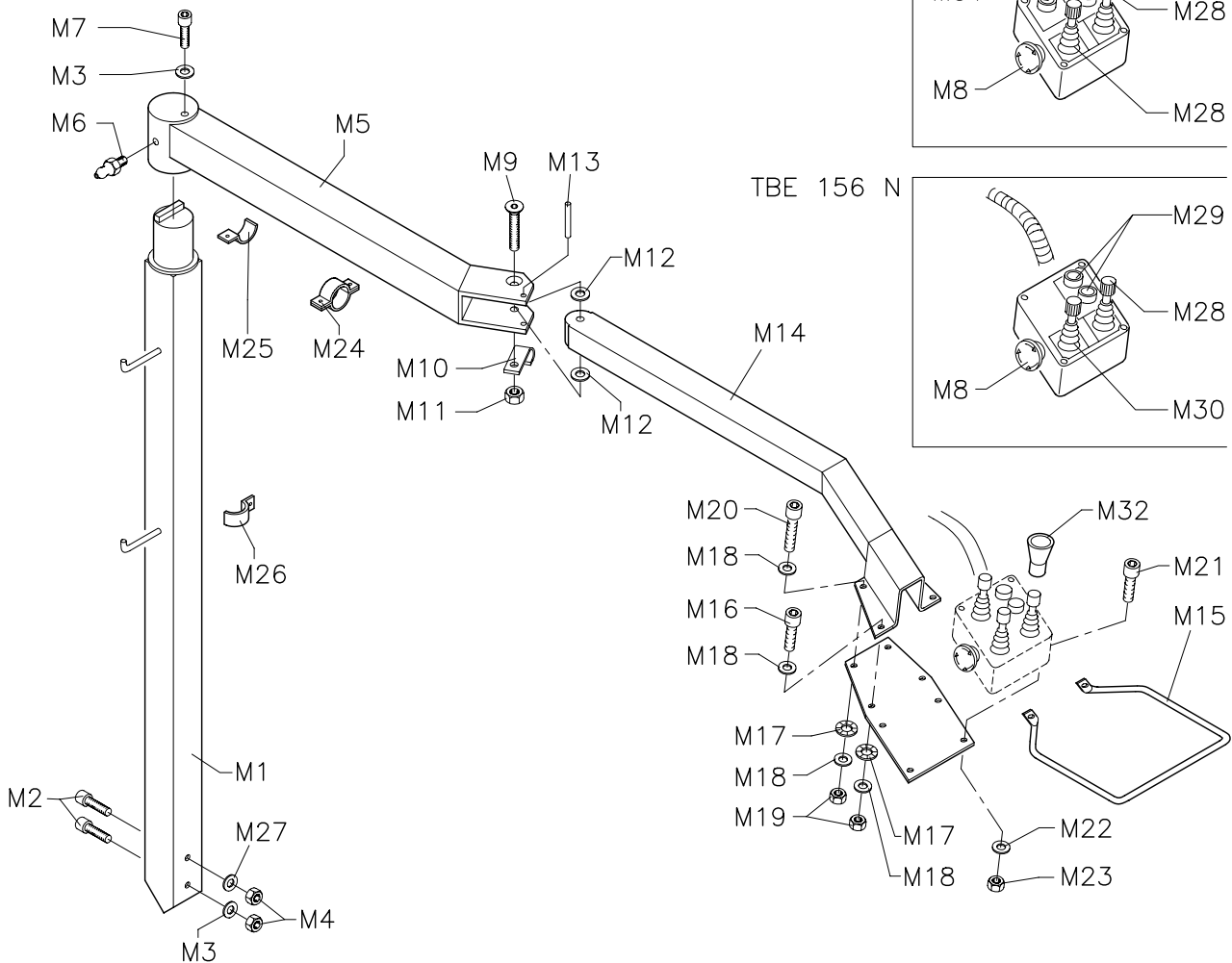
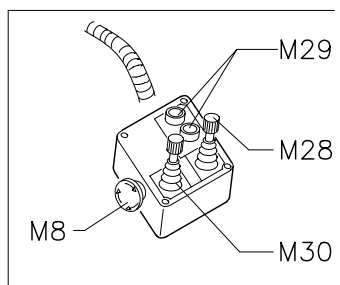

IMPORTANTE: per la richiesta dei ricambi far riferimento al codice ricambi (vedi pag. 30).
IMPORTANT: for the request of spare parts please refer to spare parts code (see page 30).
IMPORTANT: pour la demande de pièces de rechange faire référence au code des pièces de rechange (voir pages 30).
WICHTIG: für die Anforderung von Ersatzteilen die Ersatzteilcodes (siehe Seite 30) angeben.
IMPORTANTE: para pedir los repuestos remitirse al código repuestos (ver pag. 30).

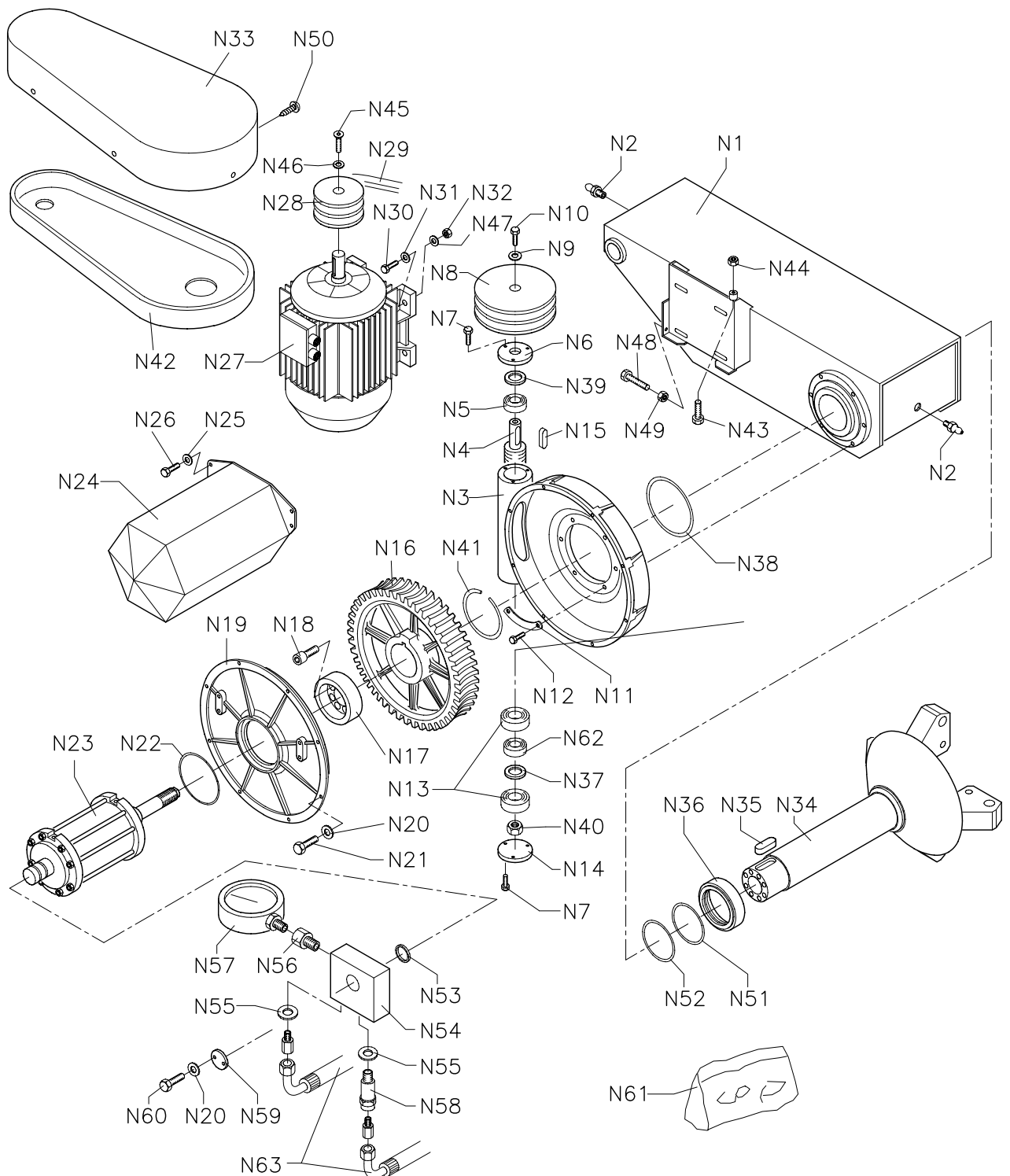

IMPORTANTE: per la richiesta dei ricambi far riferimento al codice ricambi (vedi pag. 31).

IMPORTANT: for the request of spare parts please refer to spare parts code (see page 31).

IMPORTANT: pour la demande de pièces de rechange faire référence au code des pièces de rechange (voir pages 31).

WICHTIG: für die Anforderung von Ersatzteilen die Ersatzteilcodes (siehe Seite 31) angeben.

IMPORTANTE: para pedir los repuestos remitirse al código repuestos (ver pag. 31).

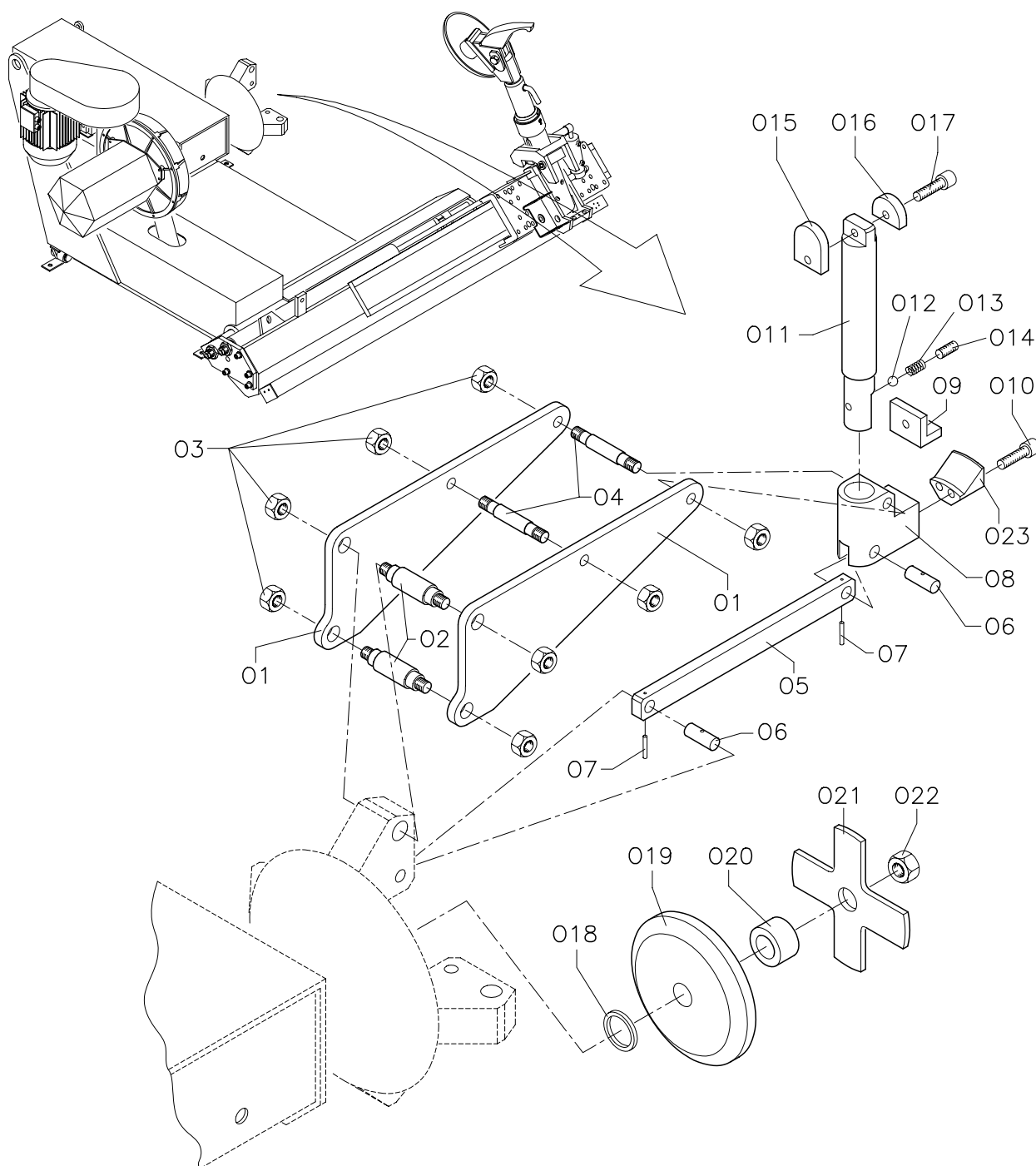

IMPORTANTE: per la richiesta dei ricambi far riferimento al codice ricambi (vedi pag. 32).
IMPORTANT: for the request of spare parts please refer to spare parts code (see page 32).
IMPORTANT: pour la demande de pièces de rechange faire référence au code des pièces de rechange (voir pages 32).
WICHTIG: für die Anforderung von Ersatzteilen die Ersatzteilcodes (siehe Seite 32) angeben.
IMPORTANTE: para pedir los repuestos remitirse al código repuestos (ver pag. 32).

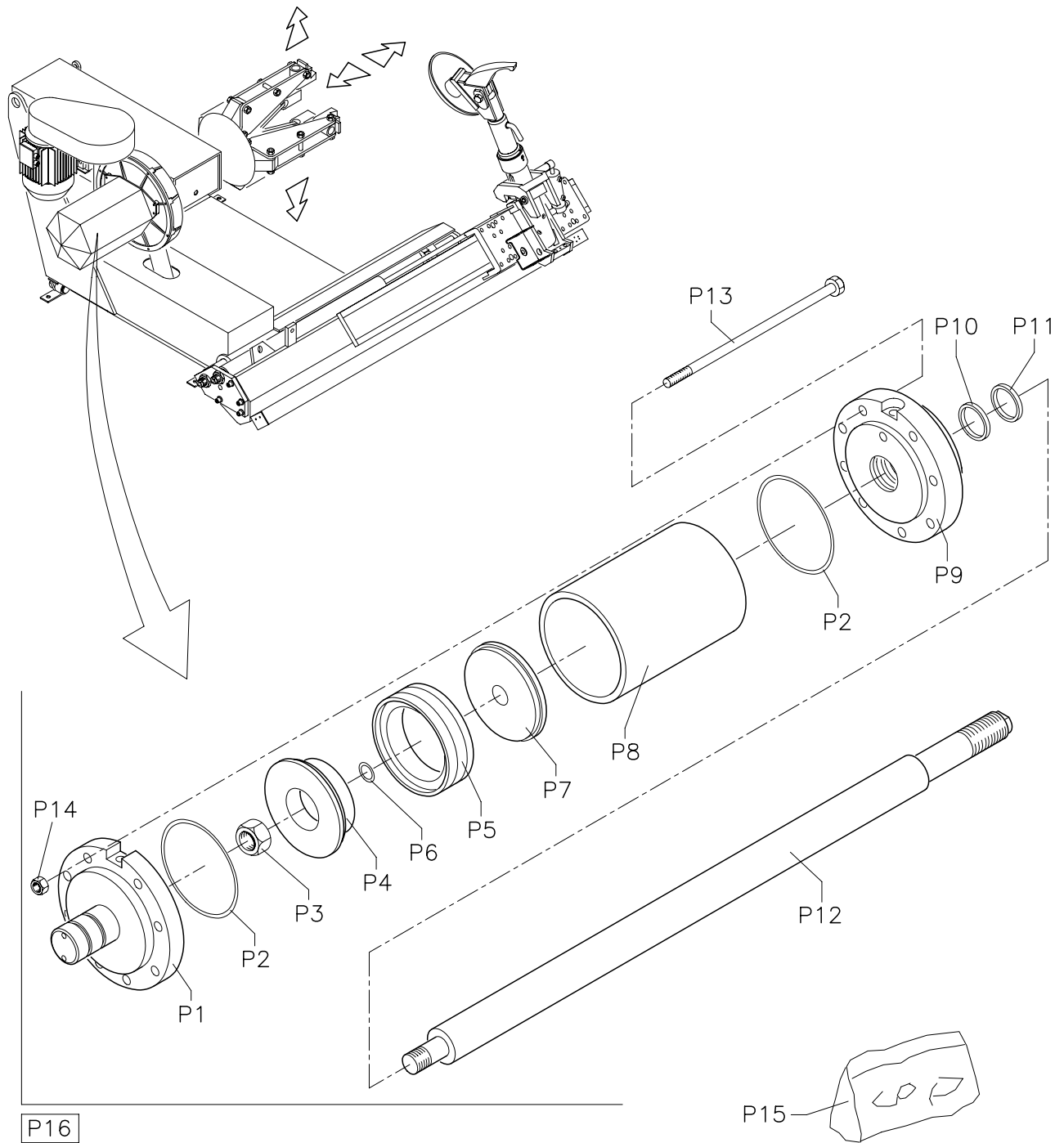

IMPORTANTE: per la richiesta dei ricambi far riferimento al codice ricambi (vedi pag. 32).
IMPORTANT: for the request of spare parts please refer to spare parts code (see page 32).
IMPORTANT: pour la demande de pièces de rechange faire référence au code des pièces de rechange (voir pages 32).
WICHTIG: für die Anforderung von Ersatzteilen die Ersatzteilcodes (siehe Seite 32) angeben.
IMPORTANTE: para pedir los repuestos remitirse al código repuestos (ver pag. 32).

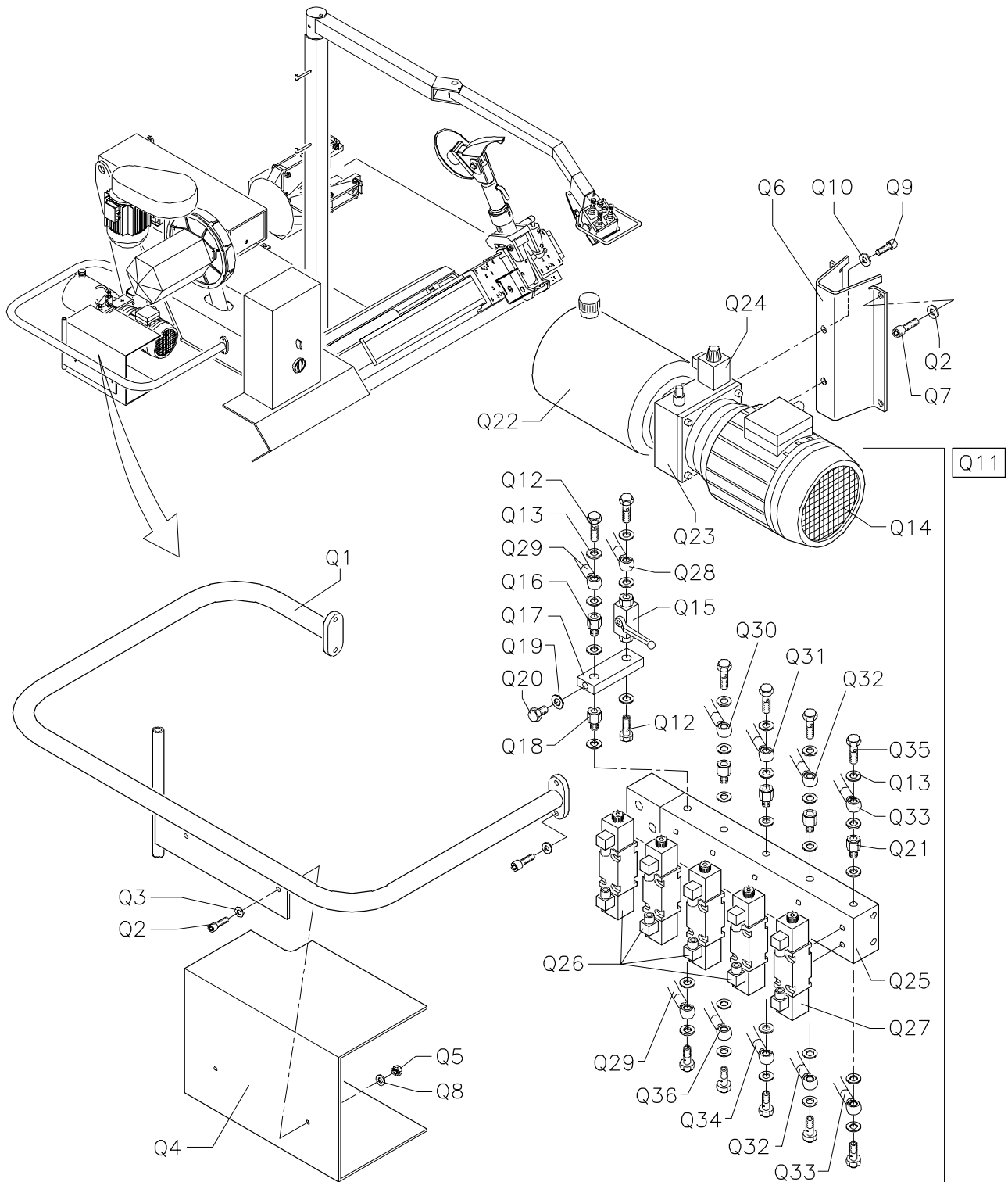

IMPORTANTE: per la richiesta dei ricambi far riferimento al codice ricambi (vedi pag. 34).
IMPORTANT: for the request of spare parts please refer to spare parts code (see page 34).
IMPORTANT: pour la demande de pièces de rechange faire référence au code des pièces de rechange (voir pages 34).
WICHTIG: für die Anforderung von Ersatzteilen die Ersatzteilcodes (siehe Seite 34) angeben.
IMPORTANTE: para pedir los repuestos remitirse al código repuestos (ver pag. 34).

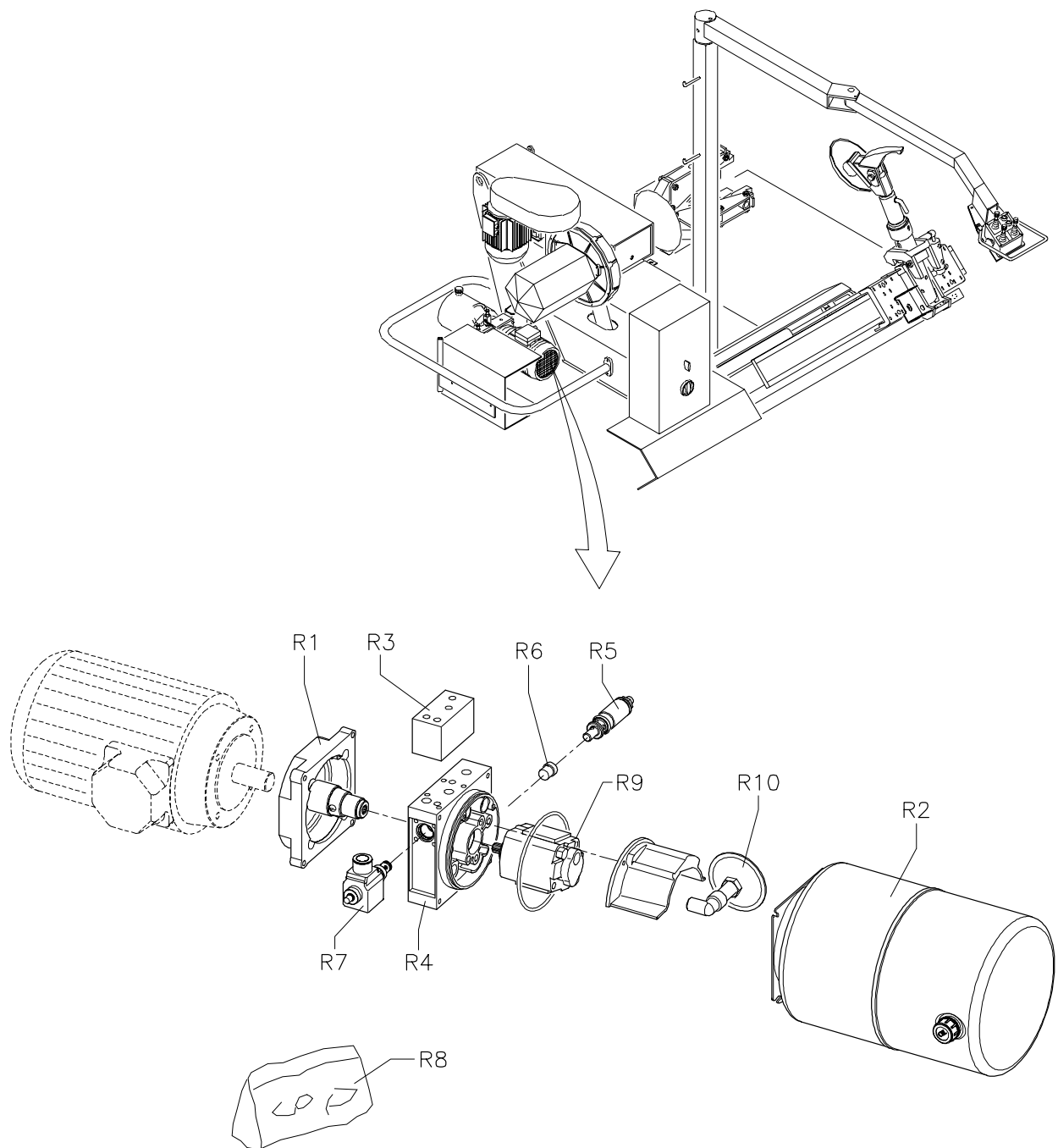

IMPORTANTE: per la richiesta dei ricambi far riferimento al codice ricambi (vedi pag. 34).
IMPORTANT: for the request of spare parts please refer to spare parts code (see page 34).
IMPORTANT: pour la demande de pièces de rechange faire référence au code des pièces de rechange (voir pages 34).
WICHTIG: für die Anforderung von Ersatzteilen die Ersatzteilcodes (siehe Seite 34) angeben.
IMPORTANTE: para pedir los repuestos remitirse al código repuestos (ver pag. 34).

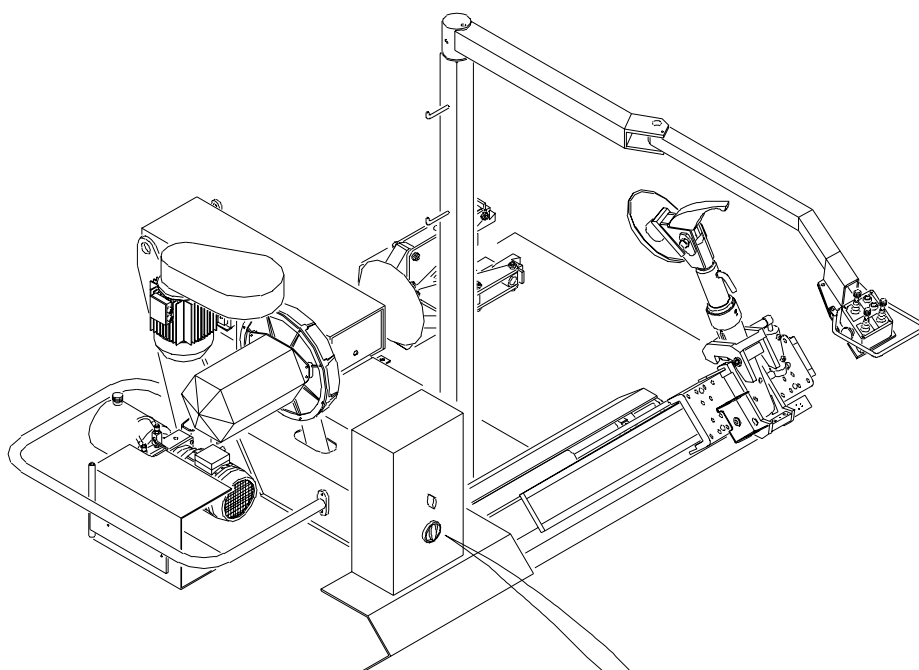

S12

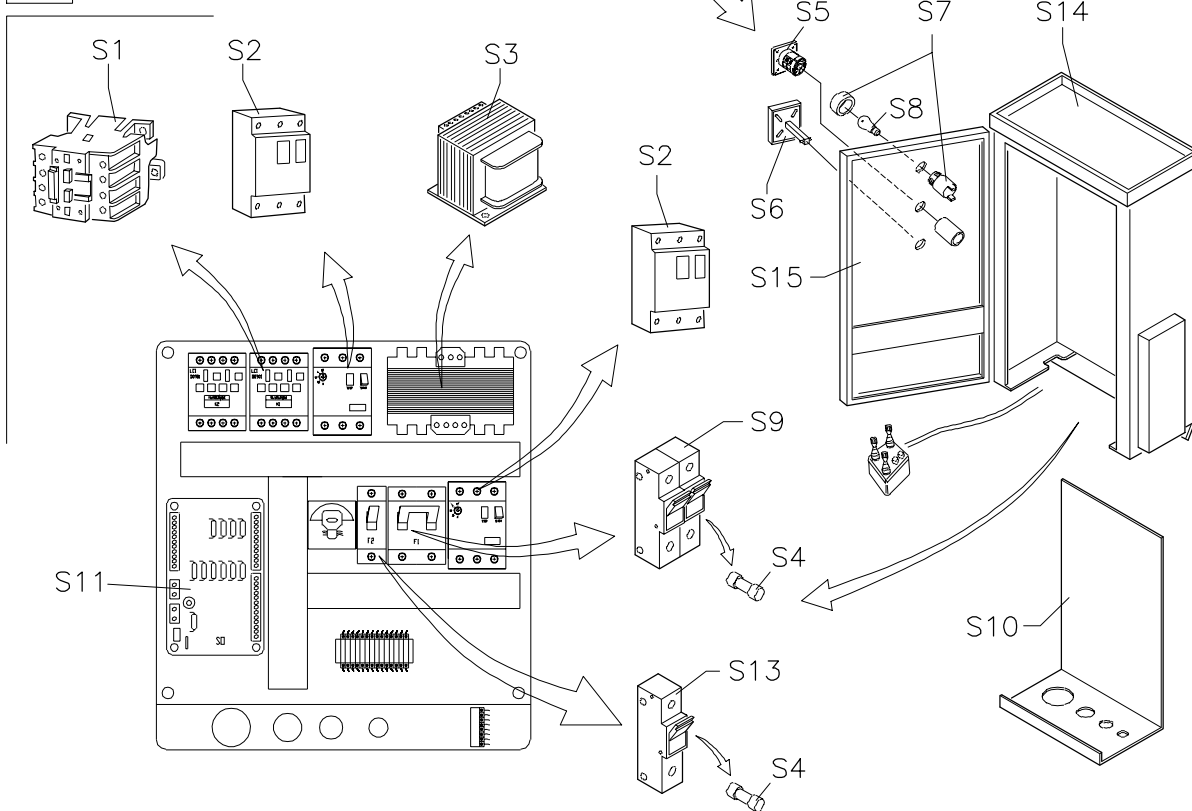

IMPORTANTE: per la richiesta dei ricambi far riferimento al codice ricambi (vedi pag. 35).
IMPORTANT: for the request of spare parts please refer to spare parts code (see page 35).
IMPORTANT: pour la demande de pièces de rechange faire référence au code des pièces de rechange (voir pages 35).
WICHTIG: für die Anforderung von Ersatzteilen die Ersatzteilcodes (siehe Seite 35) angeben.
IMPORTANTE: para pedir los repuestos remitirse al código repuestos (ver pag. 35).





TABELLA RICAMBI
SPARE PARTS CODE
TABLE PIECES DE RECHANGE
ERSATZTEILLISTE
TABLA REPUESTOS

TBE 156 S
TBE 156 DL
TBE 156 N

Posizione Position Position Position Posicion	Codice ricambio Spare parts code Code rechanger Ersatzteilcode Codigo repuesto	Descrizione Description Description Beschreibung Descripción	Posizione Position Position Position Posicion	Codice ricambio Spare parts code Code rechanger Ersatzteilcode Codigo repuesto	Descrizione Description Description Beschreibung Descripción
TAV. A			A24	35019978	TUBO FLEX HOSE
A1	36019361	BASAMENTO BASE	A25	32012121	MORSETTO MOUNTING CLAMP
A2	36020795	STRUTTURA MOBILE MOBILE STRUCTURE	A26	32008914	MORSETTO MOUNTING CLAMP
A3	32020766	CILINDRO BRACCIO MOBILE MOBILE ARM CYLINDER	A27	81010016	RONDELLA D.16 WASHER D.16
A4	33015465	PERNO CIL. BRACCIO MOBILE CYLINDRICAL PIN FOR MOBILE ARM	A28	80038092	VITE TE M16x40 BOLT M16x40
A5	33013671	RONDELLA WASHER	A29	86500008	GUARNIZIONE GASKET
A6	81120006	RONDELLA M6 WASHER M6	A30	81800800	INGRASSATORE GREASER
A7	80038024	VITE TE M6x16I BOLT M6x16I	A31	81010026	RONDELLA D.26 WASHER D.26
A8	33019713	PERNO FULCRO BRACCIO MOBILE MOBILE ARM FULCRUM PIN	A32	80455020	DADO AUT.B M20 LOCK-NUT B M20
A9	33020826	RONDELLA WASHER	A33	88903240	BOCCOLA SINTERIZZATA 32x40 SINTERED BUSHING 32x40
A10	80050100	VITE TPSCE M20x40 FLATHEAT SCREW M20x40	A34	84990547	PASSACAVO IN GOMMA RUBBER CABLE SHEATH
A11	36020164	RONDELLA PERNO BR. MOBILE MOBILE ARM PIN WASHER	A35	36019980	TUBO IDRAULICO HYDRAULIC HOSE
A12	81120008	RONDELLA DENT. ø8 TOOTHED WASHER ø8	A36	35020156	TUBO FLEX HOSE
A13	80038036	VITE TE M8x20 BOLT M8x20	A37	85200051	RACCORDO IDR. T 1/4" TUBO D.10 TN96 HYDRAULIC T UNION, HOSE D.10 TN96
A14	33016049	PERNO RUOTE STRUTT. MOBILE MOBILE STRUCTURE WHEEL PIN	A38	84990093	PASSACAVO GOMMA 90/160/40 RUBBER CABLE SHEATH 90/160/40
A15	32019733	RUOTA STRUTTURA MOBILE MOBILE STRUCTURE WHEEL	A39	86200021	TAPPO IDR.1/4" HYDRAULIC CAP 1/4"
A16	81010024	RONDELLA D.24 WASHER D. 24	A40	86200054	RACC.IDR.D. TUBO D.10 TN98 HYDRAULIC UNION HOSE D.10 TN98
A17	80445024	DADO AUT. M24 LOCK-NUT M24	A41	80108120	VITE TCCE M16x40 ALLEN SCREW M16x40
A18	32018914	CILINDRO STRUTTURA MOBILE MOBILE STRUCTURE CYLINDER	A42	36019429	RAMPA RAMP
A19	32018918	CILINDRO TRASL. CARRELLO CARRIAGE TRAVEL CYLINDER			
A20	36019435	PIASTRA ATTACCO CILINDRI CYLINDER CONNECTION PLATE			
A21	80355036	GHIERA M36x3 RING-NUT M36x3			
A22	86500020	GUARNIZIONE GASKET			
A23	86200005	VITE IDR.1/4" HYDRAULIC SCREW 1/4"			

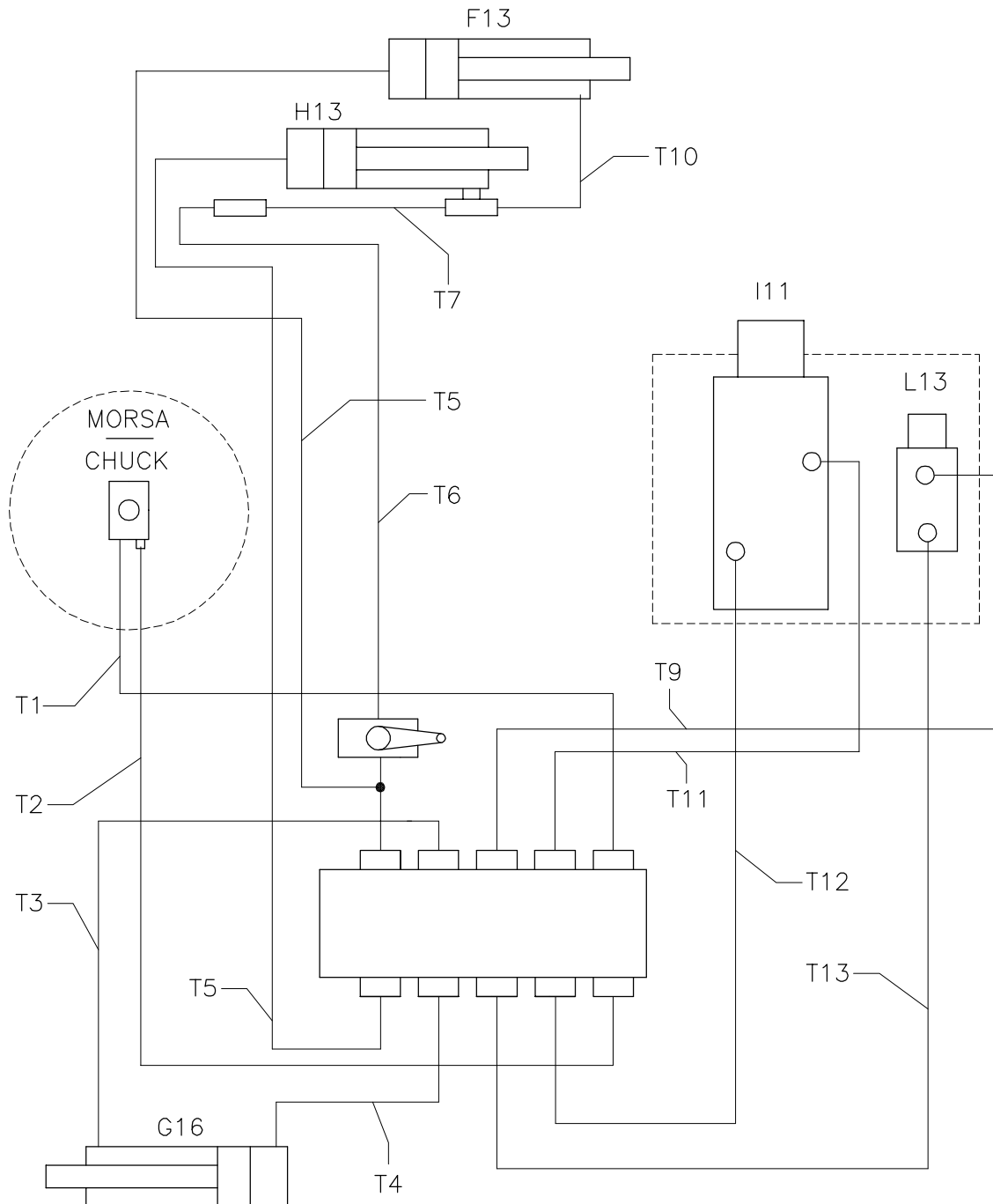

TABELLA RICAMBI
SPARE PARTS CODE
TABLE PIECES DE RECHANGE
ERSATZTEILLISTE
TABLA REPUESTOS

TBE 156 S
TBE 156 DL
TBE 156 N

Posizione Position Position Position Posicion	Codice ricambio Spare parts code Code rechanger Ersatzteilcode Codigo repuesto	Descrizione Description Description Beschreibung Descripción	Posizione Position Position Position Posicion	Codice ricambio Spare parts code Code rechanger Ersatzteilcode Codigo repuesto	Descrizione Description Description Beschreibung Descripción
TAV. B					
B1	36020898	CARRELLO TBE 156 S - TBE 156 DL CARRIAGE TBE 156 S - TBE 156 DL	B24	81010006	RONDELLA D.6 WASHER D.6
B2	36019699	SUPPORTO TUBI IDRAULICI HYDRAULIC HOSE SUPPORT	B25	80445006	DADO AUT. M6 LOCK-NUT M6
B3	80038024	VITE TE M6x16 BOLT M6x16	B26	80050041	VITE TPSCE M6x6 FLATHEAT SCREW M6x6
B4	81120006	RONDELLA D.6 WASHER D.6	B27	81010010	RONDELLA P. D.10 FLAT WASHER D.10
B5	84990547	PASSACAVO IN GOMMA 200/280/30 RUBBER CABLE SHEATH 200/280/30	B28	36020898	CARRELLO TBE 156 N CARRIAGE TBE 156 N
B6	32020951	CILINDRO BRACCIO STALLONATORE BEAD-BREAKER ARM CYLINDER	B29	80445010	DADO AUT.A. M10 LOCK-NUT M10
B7	80018085	VITE TE M16x140 BOLT M16x140	B30	4-328503	PATTINO CARRELLO CARRIAGE SLIDING BLOCK
B8	86500020	GUARNIZIONE 1/4" GASKET	B31	80018021	VITE TE M10x40 BOLT M10x40
B9	33014109	VITE FORATA 1/4" PERFORATED SCREW	B32	80018036	VITE TE M10x25 BOLT M10x25
B10	35019975	TUBO FLEX HOSE	B33	80455010	DADO AUT. B. M10 LOCK-NUT B. M10
B11	80018028	VITE TE M10x75 BOLT M10x75	B34	36020961	SUPPORTO MOLLA SPRING SUPPORT
B12	80018023	VITE TE M10x50 BOLT M10x50	B35	33020964	TAMPONE PAD
B13	81010010	RONDELLA D.10 WASHER D. 10	B36	81800800	INGRASSATORE GREASER
B14	33019920	GUAINA SHEATHING	B37	80160085	GRANO M16x20 STUD-BOLT M16x20
B15	36019417	SUPPORTO TUBI IDRAULICI HYDRAULIC HOSE SUPPORT	B38	86900010	COLLARE COLLAR
B16	80038025	VITE TE M10x20 BOLT M10x20	B39	33020075	COLLARE ALLUMINIO ALUMINIUM COLLAR
B17	36019829	COPERCHIO CANALINA TUBI HOSE RACEWAY COVER	B40	80018004	VITE TE M6x35 BOLT M6x35
B18	36019415	CARTER ANTERIORE FRONT CASING	B41	33021337	MOLLA SPRING
B19	80038022	VITE TE M6x10 BOLT M6x10			
B20	81000618	RONDELLA FL. D.6x18 SPRING WASHER D.6x18			
B21	81010016	RONDELLA D.16 WASHER D.16			
B22	80436016	DADO B. M16 NUT B. M16			
B23	80108037	VITE TCCE M6x35 ALLEN SCREW M6x35			



TABELLA RICAMBI
SPARE PARTS CODE
TABLE PIECES DE RECHANGE
ERSATZTEILLISTE
TABLA REPUESTOS

TBE 156 S
TBE 156 DL
TBE 156 N

Posizione Position Position Position Posicion	Codice ricambio Spare parts code Code rechanger Ersatzteilcode Codigo repuesto	Descrizione Description Description Beschreibung Descripción	Posizione Position Position Position Posicion	Codice ricambio Spare parts code Code rechanger Ersatzteilcode Codigo repuesto	Descrizione Description Description Beschreibung Descripción
TAV. C			C24	36019637	UTENSILE BASCULANTE SWINGING TOOL
C1	36020912	BRACCIO STALLONATORE BEAD-BREAKER ARM	C25	81450850	SPINA ELASTICA D.8x50 SPRING PIN D.8x50
C2	33015670	PERNO PIN	C26	36019619	DISCO STALLONATORE BEAD-BREAKER DISC
C3	33012944	PERNO PIN	C27	33020004	RONDELLA DISCO STALL. BEAD-BREAKER DISC WASHER
C4	36015664	PIASTRINO PLATE	C28	80108034	VITE TCCE M6x16 ALLEN SCREW M6x16
C5	80038022	VITE TE M6x10 BOLT M6x10	C29	81010006	RONDELLA D.6 WASHER D.6
C6	81810845	INGRASSATORE GREASER	C30	80172040	GRANO M8x20 STUD BOLT M8x20
C7	4-326730	PERNO PIN	C31	80436080	DADO B. M8 NUT B. M8
C8	36022294	GANCIO BRACCIO STALL. BEAD-BREAKER ARM HOOK	C32	81010016	RONDELLA D.16 WASHER D.16
C9	81470430	COPIGLIA M4x30 SPLIT-PIN M4x30	C33	81278010	SEEGER PS SNAP RING PS
C10	86500020	GIARNIZIONE RAME 1/4" COPPER GASKET	C34	85602325	OR 2325 O-RING 2325
C11	86200025	COLONNETTA MF 1/4" MF STUD	C35	81410100	ANELLO EL. SPRING RING
C12	35019976	TUBO FLEX HOSE	C36	85602375	OR 2375 O-RING 2375
C13	33014109	VITE IDRAULICA HYDRAULIC SCREW	C37	85603237	OR 3237 O-RING 3237
C14	32018934	KIT CILINDRO ROTAZIONE BRACCIO STALLONATORE BEAD-BREAKER ARM ROTATION CYLINDER KIT	C38	81240022	RONDELLA SICUREZZA D.22 SAFETY WASHER D.22
C15	33015669	PERNO PIN	C39	81900015	SPESSORE THICKNESS
C16	33019646	BRACCIO UTENSILE ROTANTE ROTATING TOOL ARM	C40	4-326731	BOCCOLA BUSH
C17	33015719	PERNO PROLUNGA UTENSILE TOOL EXTENSION PIN	C41	422677	DADO M22 NUT M22
C18	81300016	SEEGER EST. D.16 EXT. SNAP RING D.16			
C19	81470003	COPIGLIA SAGOMATA D.3 SHAPED SPLIT RING D.3			
C20	33019674	ANELLO T RING			
C21	36019626	SUPPORTO DISCO STALL. BEAD-BREAKER DISC SUPPORT			
C22	33019639	PERNO UTENSILE TOOL PIN			
C23	33019703	MOLLA DI TRAZIONE TRACTION SPRING			



TABELLA RICAMBI
SPARE PARTS CODE
TABLE PIECES DE RECHANGE
ERSATZTEILLISTE
TABLA REPUESTOS

TBE 156 S
TBE 156 DL
TBE 156 N

Posizione Position Position Position Posicion	Codice ricambio Spare parts code Code rechanger Ersatzteilcode Codigo repuesto	Descrizione Description Description Beschreibung Descripción	Posizione Position Position Position Posicion	Codice ricambio Spare parts code Code rechanger Ersatzteilcode Codigo repuesto	Descrizione Description Description Beschreibung Descripción
TAV. D			D24	85602375	OR 2375 O-RING 2375
D1	36020913	BRACCIO STALLONATORE BEAD-BREAKER ARM	D25	81410100	ANELLO EL. SPRING WASHER
D2	33015670	PERNO PIN	D26	85603237	OR 3237 O-RING 3237
D3	33019703	MOLLA SPRING	D27	36019626	SUPPORTO DISCO STALL. BEAD-BREAKER DISC SUPPORT
D4	35020610	RUOTA WHEEL	D28	33019639	PERNO UTENSILE TOOL PIN
D5	33020611	BOCCOLA BUSHING	D29	81240022	RONDELLA SICUREZZA D.22 SAFETY WASHER D.22
D6	1010008	RONDELLA D8 WASHER D8	D30	33019703	MOLLA DI TRAZIONE TRACTION SPRING
D7	80038036	VITE TE M8x20 BOLT M8x20	D31	36019637	UTENSILE BASCULANTE SWINGING TOOL
D8	81810845	INGRASSATORE GREASER	D32	81450850	SPINA ELASTICA D.8x50 SPRING PIN D.8x50
D9	33020574	PERNO PIN	D33	81900015	SPESSORE SHIM
D10	4-326730	PERNO PIN	D34	36019619	DISCO STALLONATORE BEAD-BREAKER DISC
D11	36022294	GANCIO BRACCIO STALLONATORE BEAD-BREAKER ARM HOOK	D35	33020004	RONDELLA DISCO STALL. BEAD-BREAKER DISC WASHER
D12	81010016	RONDELLA D.16 WASHER D.16	D36	80108034	VITE TCCE M6x16 ALLEN SCREW M6x16
D13	81470430	COPIGLIA M4x30 SPLIT-PIN M4x30	D37	4-326731	BOCCOLA BUSH
D14	80172040	GRANO M8x20 STUD-BOLT M8x20	D38	422677	DADO M22 NUT M22
D15	80436080	DADO B. M8 NUT B. M8			
D16	36020572	PEDALE SGANCIO RELEASE PEDAL			
D17	36020344	BRACCIO UTENSILE ROTANTE ROTATING TOOL ARM			
D18	33015719	PERNO PROLUNGA UTENSILE TOOL EXTENSION PIN			
D19	81300016	SEEGER EST. D.16 EXT. SNAP RING D.16			
D20	81470003	COPIGLIA SAGOMATA D.3 SHAPED SPLIT-PIN D.3			
D21	81278010	SEEGER PS SNAP RING PS			
D22	33019674	ANELLO TENUTA BRACCIO ROTANTE ROTARY ARM RETAINER RING			
D23	85602325	OR 2325 O-RING 2325			



TABELLA RICAMBI
SPARE PARTS CODE
TABLE PIÈCES DE RECHANGE
ERSATZTEILLISTE
TABLA REPUESTOS

TBE 156 S
TBE 156 DL
TBE 156 N

Posizione Position Position Position Posicion	Codice ricambio Spare parts code Code rechanger Ersatzteilcode Codigo repuesto	Descrizione Description Description Beschreibung Descripción	Posizione Position Position Position Posicion	Codice ricambio Spare parts code Code rechanger Ersatzteilcode Codigo repuesto	Descrizione Description Description Beschreibung Descripción
TAV. E			TAV. F		
E1	36020914	BRACCIO STALLONATORE TBE 156 N BEAD-BREAKER ARM TBE 156 N	F1	36018915	FONDELLO + CANNA BOTTOM + BARREL
E2	33015670	PERNO PIN	F2	80355022	DADO AUT. B M22x1,5 LOCK-NUT B M22x1.5
E3	35009892	TAMPONE PAD	F3	33011046	PISTONE POSTERIORE REAR PISTON
E4	33009975	MOLLA TAMPONE PAD SPRING	F4	85603087	GUARNIZIONE OR 3087 A+P O-RING GASKET 3087 A+P
E5	33009891	TAPPO CAP	F5	86500061	GUARNIZIONE DBM 275196 POLYPAC GASKET DBM 275196 POLYPAC
E6	33015719	PERNO PROLUNGA UTENSILE TOOL EXTENSION PIN	F6	33011354	PISTONE ANTERIORE FRONT PISTON
E7	81300016	SEEGER EST. D.16 EXT. SNAP RING D.16	F7	85600171	GUARNIZIONE OR 171 A+P O-RING GASKET 171 A+P
E8	81470003	COPIGLIA SAGOMATA D.3 SHAPED SPLIT-PIN D.3	F8	33011041	TESTATA CILINDRO CYLINDER HEAD
E9	36020904	GANCIO BRACCIO STALLONATORE TBE 156 N BEAD-BREAKER ARM HOOK TBE 156 N	F9	86500035	GUARNIZIONE B 236196 POLYPAC GASKET B 236196 POLYPAC
E10	80108158	VITE TCCE M24x40 ALLEN SCREW M24x40	F10	86500119	GUARNIZIONE UWR 196228 POLYPAC GASKET UWR 196228 POLYPAC
E11	33010279	MOLLA SPRING	F11	33018917	STELO CILINDRO CYLINDER ROD
E12	36019626	SUPPORTO DISCO STALL. BEAD-BREAKER DISC SUPPORT	F12	86518914	KIT GUARNIZIONI CILINDRO 32018914 CYLINDER GASKET KIT 32018914
E13	33019639	PERNO UTENSILE TOOL PIN	F13	32018914	KIT CILINDRO STRUTTURA MOBILE MOBILE STRUCTURE CYLINDER KIT
E14	81240022	RONDELLA WASHER			
E15	33019703	MOLLA SPRING			
E16	36019637	UTENSILE BASCULANTE SWINGING TOOL			
E17	81450850	SPINA ELASTICA D.8x50 SPRING PIN D.8x50			
E18	81900015	SPESSORE SHIM			
E19	81810845	INGRASSATORE GREASER			
E20	36019619	DISCO STALLONATORE BEAD-BREAKER DISC			
E21	33020004	RONDELLA DISCO STALLONATORE BEAD-BREAKER DISC WASHER			
E22	80108034	VITE TCCE M6x16 ALLEN SCREW M6x16			



TABELLA RICAMBI
SPARE PARTS CODE
TABLE PIECES DE RECHANGE
ERSATZTEILLISTE
TABLA REPUESTOS

TBE 156 S
TBE 156 DL
TBE 156 N

Posizione Position Position Position Posicion	Codice ricambio Spare parts code Code rechanger Ersatzteilcode Codigo repuesto	Descrizione Description Description Beschreibung Descripción	Posizione Position Position Position Posicion	Codice ricambio Spare parts code Code rechanger Ersatzteilcode Codigo repuesto	Descrizione Description Description Beschreibung Descripción
TAV. G			TAV. H		
G1	36021651	FONDELLO + CANNA BOTTOM + BARREL	H1	36018919	CANNA + FONDELLO BARREL + BOTTOM
G2	33016630	DISTANZIALE BOCCOLE BUSHING SPACER	H2	80355022	DADO AUT. B M22x1,5 UNI 7474 LOCK-NUT B M22x1.5 UNI 7474
G3	88903015	BOCCOLA ANTIFRIZIONE DU 30-15 FRICTION BUSHING DU 30-15	H3	33011046	PISTONE POSTERIORE REAR PISTON
G4	80355022	DADO AUT. B M22x1,5 UNI 7474 LOCK-NUT B M22x1.5 UNI 7474	H4	85603087	GUARNIZIONE OR 3087 A+P O-RING GASKET 3087 A+P
G5	33019517	PISTONE POSTERIORE REAR PISTON	H5	86500063	GUARNIZIONE DBM 236173 POLYPAC GASKET DBM 236173 POLYPAC
G6	85604112	GUARNIZIONE OR 4112 A+P O-RING GAS KET 4112 A+P	H6	33011355	PISTONE ANTERIORE FRONT PISTON
G7	86500028	GUARNIZIONE DBM 248185 GASKET DBM 248185	H7	85600162	GUARNIZIONE OR 162 A+P O-RING GASKET 162 A+P
G8	33019516	PISTONE ANTERIORE FRONT PISTON	H8	33011042	TESTATA CILINDRO CYLINDER HEAD
G9	85600838	GUARNIZIONE OR DOWTY 838 O-RING GASKET DOWTY 838	H9	86500039	GUARNIZIONE B 169137 POLYPAC GASKET B 169137 POLYPAC
G10	33008668	TESTATA HEAD	H10	86500118	GUARNIZIONE UWR 137169 POLYPAC GASKET UWR 137169 POLYPAC
G11	86500027	GUARNIZIONE B 169141 POLYPAC GASKET B 169141 POLYPAC	H11	33018922	STELO ROD
G12	86500117	GUARNIZIONE UWR 141173 POLYPAC GASKET UWR 141173 POLYPAC	H12	86518918	KIT GUARNIZIONI CILINDRO 32018918 CYLINDER GASKET KIT 32018918
G13	36021649	STELO + ATTACCO ROD + CONNECTION	H13	32018918	KIT CILINDRO TRASLAZIONE CARRELLO CARRIAGE TRAVEL CYLINDER KIT
G14	88903030	BOCCOLA ANTIFRIZIONE DU 30-30 FRICTION BUSHING DU 30-30			
G15	86518923	KIT GUARNIZIONI CILINDRO 32018923 CYLINDER GASKET KIT 32018923			
G16	32021648	KIT CILINDRO BRACCIO MOBILE MOBILE ARM CYLINDER KIT			



TABELLA RICAMBI
SPARE PARTS CODE
TABLE PIÈCES DE RECHANGE
ERSATZTEILLISTE
TABLA REPUESTOS

TBE 156 S
TBE 156 DL
TBE 156 N

Posizione Position Position Position Posicion	Codice ricambio Spare parts code Code rechanger Ersatzteilcode Codigo repuesto	Descrizione Description Description Beschreibung Descripción	Posizione Position Position Position Posicion	Codice ricambio Spare parts code Code rechanger Ersatzteilcode Codigo repuesto	Descrizione Description Description Beschreibung Descripción
TAV. I			TAV. L		
11	36018929	CANNA + FONDELLO BARREL + BOTTOM	L1	36012926	CANNA + FONDELLO BARREL + BOTTOM
12	33008674	PISTONE PISTON	L2	80172028	VITE M6x12 UNI 5925 SCREW M6x12 UNI 5925
13	86500030	GUARNIZIONE GASKET	L3	33012928	PISTONE PISTON
14	86503050	GUARNIZIONE GASKET	L4	85602037	GUARNIZIONE OR 2037 A+P O-RING GASKET 2037 A+P
15	85600829	OR 829 DOWTY O-RING 829 DOWTY	L5	86500079	GUARNIZIONE E/GR 0300 POLYPAC GASKET E/GR 0300 POLYPAC
16	33008672	FONDELLO ANTERIORE FRONT END	L6	85602112	GUARNIZIONE OR 2112 A+P O-RING GASKET OR 2112 A+P
17	86500031	GUARNIZIONE GASKET	L7	33016697	FONDELLO ANTERIORE FRONT END
18	86500120	GUARNIZIONE GASKET	L8	86500076	GUARNIZIONE IGR 0160 POLYPAC GASKET IGR 0160 POLYPAC
19	36020953	STELO ROD	L9	86500121	GUARNIZIONE UWR 062087 POLYPAC GASKET UWR 062087 POLYPAC
110	86518918	KIT GUARNIZIONI CILINDRO 32018928 CYLINDER GASKET KIT 32018928	L10	81410032	SEEGER SNAP RING
111	32020951	KIT CILINDRO SOLLEVAMENTO BRACCI STALLONATORE BEAD-BREAKER ARM LIFTING CYLINDER KIT	L11	36018935	STELO ROD
			L12	86518934	KIT GUARNIZIONI CILINDRO 32018934 CYLINDER SEAL KIT 32018934
			L13	32018934	KIT CILINDRO ROTAZIONE UTENSILE TOOL ROTATION CYLINDER KIT



TABELLA RICAMBI
SPARE PARTS CODE
TABLE PIECES DE RECHANGE
ERSATZTEILLISTE
TABLA REPUESTOS

TBE 156 S
TBE 156 DL
TBE 156 N

Posizione Position Position Position Posicion	Codice ricambio Spare parts code Code rechanger Ersatzteilcode Codigo repuesto	Descrizione Description Description Beschreibung Descripción	Posizione Position Position Position Posicion	Codice ricambio Spare parts code Code rechanger Ersatzteilcode Codigo repuesto	Descrizione Description Description Beschreibung Descripción
TAV. M			M24	84990073	COLLARE COLLAR
M1	36019686	COLONNA BRACCIO COMANDI CONTROLS ARM COLUMN	M25	84990003	COLLARE COLLAR
M2	80038054	VITE TE M10x40 BOLT M10x40	M26	84990022	STAFFETTA BRACKET
M3	81010010	RONDELLA M10 WASHER	M27	81001040	RONDELLA FL. 10x40 SPRING RING 10x40
M4	80415010	DADO AUT. A M10 LOCK-NUT A M10	M28	84600001	MANIPOLATORE 4 VIE 4-WAY CONTROL MODULE
M5	36019693	BRACCIO COMANDI ORIZZONTALE HORIZONTAL CONTROLS ARM	M29	84400009	PULSANTE PUSH-BUTTON
M6	81800800	INGRASSATORE GREASER	M30	84600002	MANIPOLATORE 2 VIE 2-WAY CONTROL MODULE
M7	80108069	VITE TCCE M10x20 ALLEN SCREW M10x20	M31	84400075	PULSANTE PUSH-BUTTON
M8	84400058	PULSANTE A FUNGO MUSHROOM-HEAD BUTTON	M32	35022371	PROTEZIONE PROTECTION
M9	80050087	VITE TPSCE M12x80 UNI 5931 88 FLATHEAD M12x80 UNI 5931 88			
M10	36015689	LAMA BLADE			
M11	80445012	DADO AUT. M12 PG UNI 7473 5S LOCK-NUT M12 PG UNI 7473 5S			
M12	81120012	RONDELLA D.12 WASHER D.12			
M13	81450860	SPINA ELASTICA 8x60 UNI 6873 SPRING PIN 8x60 UNI 6873			
M14	36019695	BRACCIO PORTACOMANDI CONTROLS ARM			
M15	36020128	MANIGLIA SCATOLA COMANDI CONTROL BOX HANDLE			
M16	80108034	VITE TCCE M6x16 ALLEN SCREW M6x16			
M17	81200006	RONDELLA D.6 WASHER D.6			
M18	81010006	RONDELLA D.6 WASHER D.6			
M19	80416006	DADO A M6 NUT A M6			
M20	80108035	VITE TCCE M6x20 ALLEN SCREW M6x20			
M21	80108006	VITE TCCE M4x16 ALLEN SCREW M4x16			
M22	81010004	RONDELLA D.4 WASHER D.4			
M23	80445004	DADO AUT.A M14 LOCK-NUT A M14			



TABELLA RICAMBI
SPARE PARTS CODE
TABLE PIECES DE RECHANGE
ERSATZTEILLISTE
TABLA REPUESTOS

TBE 156 S
TBE 156 DL
TBE 156 N

Posizione Position Position Position Posicion	Codice ricambio Spare parts code Code rechanger Ersatzteilcode Codigo repuesto	Descrizione Description Description Beschreibung Descripción	Posizione Position Position Position Posicion	Codice ricambio Spare parts code Code rechanger Ersatzteilcode Codigo repuesto	Descrizione Description Description Beschreibung Descripción
TAV. N			N25	81010008	RONDELLA D.8 WASHER D.8
N1	36021673	BRACCIO MOBILE MOBILE ARM	N26	80038036	VITE TE M8x20 BOLT M8x20
N2	81800800	INGRASSATORE GREASER	N27	83933317	MOTORE EL. 3 PHASE 380V. RIDUTTORE 2°V ELECTRIC MOTOR, 3 PHASE, 380V. 2ND SPEED REDUCTION GEAR
N3	354212	SCATOLA RIDUTTORE REDUCTION GEARBOX		83933217	MOTORE EL. 3 PHASE 220V. RIDUTTORE 2°V ELECTRIC MOTOR, 3 PHASE, 220V. 2ND SPEED REDUCTION GEAR
N4	317275	VITE SCREW	N28	355692	PULEGGIA PULLEY
N5	602213	CUSCINETTO BEARING	N29	3-00577	CINGHIA BELT
N6	354876	COPERCHIO ANTERIORE FRONT COVER	N30	80038038	VITE TE M8x30 BOLT M8x30
N7	80108038	VITE TCCE M6x30 ALLEN SCREW M6x30	N31	81010008	RONDELLA D.8 WASHER D.8
N8	355893	PULEGGIA PULLEY	N32	80445008	DADO AUT.A M8 LOCK-NUT A M8
N9	317339	RONDELLA WASHER	N33	455891	CARTER CASING
N10	80108071	VITE TE M10x30 BOLT M10x30	N34	36020819	ALBERO MANDRINO SPINDLE SHAFT
N11	33020166	PIASTRA PLATE	N35	81502060	LINGUETTA 20x12x60 TANG 20x12x60
N12	80108092	VITE TE M12x30 BOLT M12x30	N36	33020821	DISTANZIALE ALBERO MANDRINO SPINDLE SHAFT SPACER
N13	2-01035	CUSCINETTO BEARING	N37	317281	DISTANZIALE CUSCINETTO BEARING SPACER
N14	354875	COPERCHIO POSTERIORE REAR COVER	N38	85603725	OR 3725 O-RING 3725
N15	81500835	CHIAVETTA 8x7x35 KEY 8x7x35	N39	317281	DISTANZIALE SPACER
N16	341541	RUOTA WHEEL	N40	2-00663	DADO BLOCCAGGIO VITE BOLT LOCK NUT
N17	33019919	FLANGIA FLANGE	N41	81279002	SEEGER PS 90x110x2 SNAP RING PS 90x110x2
N18	80102071	VITE TCCE M12x30 ALLEN SCREW M12x30	N42	353245	CARTER INFERIORE LOWER CASING
N19	354213	FONDO RIDUTTORE REDUCTION GEAR BASE	N43	80038015	VITE TE M5x10 BOLT M5x10
N20	81010006	RONDELLA D.6 WASHER D.6	N44	81010005	RONDELLA D.5 WASHER D.5
N21	80038025	VITE M6x20 SCREW M6x20	N45	2-02024	VITE TPSCE M8x20 FLATHEAD SCREW M8x20
N22	86500129	GUARNIZIONE SM 11013012 GASKET SM 11013012	N46	81010014	RONDELLA D.14 WASHER D.14
N23	32020823	CILINDRO MANDRINO SPINDLE CYLINDER			
N24	36019680	CARTER CILINDRO MORSA CLAMP CYLINDER GUARD			



TABELLA RICAMBI
SPARE PARTS CODE
TABLE PIECES DE RECHANGE
ERSATZTEILLISTE
TABLA REPUESTOS

TBE 156 S
TBE 156 DL
TBE 156 N

Posizione Position Position Position Posicion	Codice ricambio Spare parts code Code rechanger Ersatzteilcode Codigo repuesto	Descrizione Description Description Beschreibung Descripción	Posizione Position Position Position Posicion	Codice ricambio Spare parts code Code rechanger Ersatzteilcode Codigo repuesto	Descrizione Description Description Beschreibung Descripción
N47	81000824	RONDELLA FL. D.8x24 SPRING RING. D.8x24	TAV. O		
N48	80108057	VITE TCCE M8x40 ALLEN SCREW M8x40	O1	33019614	PIASTRA MANDRINO SPINDLE PLATE
N49	80436008	DADO B M8 NUT B M8	O2	33020126	PERNO FISSAGGIO PIASTRE PLATE FIXING SCREW
N50	80110007	VITE AUTOFIL.M2.9 x 9.5 SCREW AUTOFIL.M2.9 x 9.5	O3	80466014	DADO M14 NUT M14
N51	85603350	OR 3350 O-RING 3350	O4	33020127	PERNO SUP. SUPPORTO GRIFFA UPPER PIN FOR CLAMP SUPPORT
N52	85603425	OR 3425 O-RING 3425	O5	33020124	BIELLA MANDRINO SPINDLE CONNECTING-ROD
N53	33020103	DISTANZIALE COLLETTORE MANIFOLD SPACER	O6	33020125	PERNO BIELLA CONNECTING-ROD PIN
N54	32019618	COLLETTORE MANIFOLD	O7	81450330	SPINA D.3x30 PIN D.3X30
N55	86500020	RONDELLA RAME 1/4" COPPER WASHER	O8	33021811	SUPPORTO SUPPORT
N56	86200076	RACCORDO G. D 1/4" UNION G. D 1/4"	O9	33010369	UNGHIA CLAW
N57	86100080	MANOMETRO 1/4" PRESSURE GAUGE	O10	80102057	VITE TCCE M 10x40 ALLEN SCREW M 10x40
N58	86200044	RACCORDO D .1/4" TUBO 8 UNION D. 1/4" HOSE 8	O11	33020123	PROLUNGA MANDRINO SPINDLE EXTENSION
N59	36019841	RONDELLA TENUTA COLLETTORE MANIFOLD RETAINER WASHER	O12	88901332	SFERA PROLUNGA MANDRINO 13/32" 10,319 SPINDLE EXTENSION BALL 13/32" 10,319
N60	80038024	VITE TE M 6x16 BOLT M6x16	O13	33009297	MOLLA SPRING
N61	86511134	KIT GUARNIZIONI MORSA TBE156 CLAMP GASKET KIT TBE156	O14	80162066	GRANO M14x16 UNI 5923 12.9 STUD BOLT M14x16 UNI 5923 12.9
N62	2-01034	CUSCINETTO BERAING	O15	33009141	BATTUTA CERCHI RIM STOP
N63	35019974	TUBO FLEX HOSE	O16	33009751	UNGHIA FERMACERCHIO RIM STOP CLAW
			O17	80102056	VITE TCCE M 10x35 ALLEN SCREW M 10x35
			O18	33020103	DISTANZIALE SPACER
			O19	36015240	DISCO APERTURA MORSA CLAMP OPENING DISC
			O20	36015991	DISTANZIALE CROCIERA CROSS-JOURNAL SPACER
			O21	36015992	CROCIERA CHIUSURA MORSA CLAMP CLOSING CROSS- JOURNAL
			O22	80445024	DADO AUT.A M24 NUT M 24
			O23	33021812	UNGHIA CLAW



TABELLA RICAMBI
SPARE PARTS CODE
TABLE PIECES DE RECHANGE
ERSATZTEILLISTE
TABLA REPUESTOS

TBE 156 S
TBE 156 DL
TBE 156 N

Posizione Position Position Position Posicion	Codice ricambio Spare parts code Code rechanger Ersatzteilcode Codigo repuesto	Descrizione Description Description Beschreibung Descripción	Posizione Position Position Position Posicion	Codice ricambio Spare parts code Code rechanger Ersatzteilcode Codigo repuesto	Descrizione Description Description Beschreibung Descripción
TAV. P			TAV. Q		
P1	33019553	FONDELLO POSTERIORE REAR END	Q1	36020908	PROTEZIONE CENTRALINA IDRAULICA HYDRAULIC POWER UNIT GUARD
P2	85604400	GUARNIZIONE OR 4400 A+P O-RING GASKET 4400 A+P	Q2	80108053	VITE TCCE M8x20 ALLEN SCREW M8x20
P3	80355022	DADO AUT. B M22x1,5 UNI 7474 LOCK-NUT B M22x1.5 UNI 7474	Q3	81010008	RONDELLA D.8 WASHER D.8
P4	4-328807	PISTONE POSTERIORE REAR PISTON	Q4	36021742	CARTER CENTRALINA IDRAULICA HYDRAULIC POWER UNIT GUARD
P5	86500123	GUARNIZIONE DBM433334 POLYPAC GASKET DBM433334 POLYPAC	Q5	80416008	DADO A M8 NUT A M8
P6	85603087	GUARNIZIONE OR 3087 A+P O-RING GASKET 3087 A+P	Q6	36021741	SUPPORTO CENTRALINA IDRAULICA HYDRAULIC POWER UNIT SUPPORT
P7	33019555	PISTONE ANTERIORE FRONT PISTON	Q7	80108052	VITE TCCE M8x16 ALLEN SCREW M8x16
P8	39019557	CANNA BARREL	Q8	81200008	ROSETTA DENT. M8 TOOTHED WASHER M8
P9	39019558	FONDELLO ANTERIORE FRONT END	Q9	80038050	VITE TE M10x20 BOLT M10x20
P10	86500103	GUARNIZIONE EU 4050/2 POLYPAC GASKET EU 4050/2 POLYPAC	Q10	81010010	ROSETTA P. M10 FLAT WASHER M10
P11	86500068	ANELLO DI GUIDA I/DWR 40/2 POLYPAC GUIDE RING I/DWR 40/2 POLYPAC	Q11	31410051	CENTRALINA IDRAULICA TBE 156 SUPER HYDRAULIC POWER UNIT TBE 156 SUPER
P12	33020824	STELO CILINDRO MANDRINO SPINDLE CYLINDER ROD		31410050	CENTRALINA IDRAULICA TBE 156 DELUXE HYDRAULIC POWER UNIT TBE 156 DELUXE
P13	80018037	VITE TE M10x240 UNI 5737 BOLT M10x240 UNI 5737		31410049	CENTRALINA IDRAULICA TBE 156 N HYDRAULIC POWER UNIT TBE 156 N
P14	80445010	DADO AUT. M10 DIN 982 LOCK-NUT M10 DIN 982	Q12	33014104	VITE FORATA PERFORATED SCREW
P15	86519541	KIT GUARNIZIONI CILINDRO MANDRINO SPINDLE CYLINDER GASKET KIT	Q13	86500020	ROND. RAME COPPER WASHER
P16	32020823	KIT CILINDRO MANDRINO SPINDLE CYLINDER KIT	Q14	3-01934	MOTORE CENTRALINA IDRAULICA HYDRAULIC POWER UNIT 380V
			Q15	86100011	RUBINETTO A. P. 2 VIE 1/4" 2-WAY HIGH PRESSURE COCK



TABELLA RICAMBI
SPARE PARTS CODE
TABLE PIECES DE RECHANGE
ERSATZTEILLISTE
TABLA REPUESTOS

TBE 156 S
TBE 156 DL
TBE 156 N

Posizione Position Position Position Posicion	Codice ricambio Spare parts code Code rechanger Ersatzteilcode Codigo repuesto	Descrizione Description Description Beschreibung Descripción	Posizione Position Position Position Posicion	Codice ricambio Spare parts code Code rechanger Ersatzteilcode Codigo repuesto	Descrizione Description Description Beschreibung Descripción
Q16	33014198	COLONNETTA 1/4" STUD	Q35	86200005	VITE IDR. 1/4" HYDRAULIC SCREW
Q17	33014199	PIASTRA PER TUBAZIONI 1/4" PIPELINE PLATE	Q36	35019559	TUBO FLEX HOSE
Q18	33009994	VALVOLA NR MAND X22 DELIVERY CHECK VALVE X22			
Q19	86500017	ROND. RAME 1/8" COPPER WASHER			
Q20	86200020	TAPPO 1/8" M. ID CAP 1/8" M. ID			
Q21	86200025	COLONNETTA 1/4" MF 33 STUD			
Q22	86990207	SERBATOIO TANK			
Q23	86990206	COLLETTORE MANIFOLD			
Q24	86990196	ELETTROVALVOLA A CARTUCCIA + SOLENOIDE CARTRIDGE SOLENOID VALVE + SOLENOID VALVE			
Q25	86990110	BLOCCO 5 ELETTROVALVOLE TBE156 S 5 SOLENOID VALVE BLOCK TBE156 S			
	86990114	BLOCCO 4 ELETTROVALVOLE TBE156 DL 5 SOLENOID VALVE BLOCK TBE 156 DL			
	86990113	BLOCCO 3 ELETTROVALVOLE TBE 156 N 5 SOLENOID VALVE BLOCK TBE 156 N			
Q26	86100093	ELETTROVALVOLA SOLENOID VALVE			
Q27	86100066	ELETTROVALVOLA SOLENOID VALVE			
Q28	35019979	TUBO FLEX HOSE			
Q29	35019978	TUBO FLEX HOSE			
Q30	35015560	TUBO FLEX HOSE			
Q31	35019976	TUBO FLEX HOSE			
Q32	35019975	TUBO FLEX HOSE			
Q33	35019974	TUBO FLEX HOSE			
Q34	35019976	TUBO FLEX HOSE			



TABELLA RICAMBI
SPARE PARTS CODE
TABLE PIECES DE RECHANGE
ERSATZTEILLISTE
TABLA REPUESTOS

TBE 156 S
TBE 156 DL
TBE 156 N

Posizione Position Position Position Posicion	Codice ricambio Spare parts code Code rechanger Ersatzteilcode Codigo repuesto	Descrizione Description Description Beschreibung Descripción	Posizione Position Position Position Posicion	Codice ricambio Spare parts code Code rechanger Ersatzteilcode Codigo repuesto	Descrizione Description Description Beschreibung Descripción
TAV. R			TAV. S		
R1	86990182	KIT FLANGIA+GIUNTO FLANGEE+COUPLING KIT	S1	84420022	TELERUTTORE CONTACTOR
R2	86990207	SERBATOIO TANK	S2	84500042	TERMICA 4 – 6.3 A 380V. OVERLOAD CUTOOUT 4 – 6.3A 380V.
R3	86990226	BLOCCO ELETTROVALVOLE VALVE BLOCK		84500043	TERMICA 6 – 10 A 220V. OVERLOAD CUTOOUT 10 A 220V.
R4	86990250	COLLETTORE MAINFOLD	S3	84100043	TRASFORMATORE TRANSFORMER
R5	86990208	VALVOLA DI MASSIMA RELIEF VALVE	S4	84800304	FUSIBILE 10.3x38 4A FUZE 10.3x38 4A
R6	86990251	VALVOLA RITEGNO SALVAPOMPA CHECK VALVE	S5	84710022	COMMUTATORE SWITCH
R7	86990196	ELETTROVALVOLA A CARTUCCIA SOLENOID VALVE	S6	84700028	INTERRUTTORE GENERALE MASTER SWITCH
R8	86990212	KIT GUARNIZIONI GASKET KIT	S7	84990023	GEMMA LUMINASA LAMP COVER
R9	86990209	KIT POMPA PUMP KIT	S8	84990172	LAMPADINA LAMP BULB
R10	86990210	KIT FILTRO FILTER KIT	S9	84990424	PORTAFUSIBILE 2P FUZE-HOLDER, 2P
			S10	36020835	SUPPORTO IMPIANTO EL.ETTRICO ELECTRICAL SYSTEM SUPPORT
			S11	32020608	SCHEDA 1 Velocità TBE 156 N CIRCUIT BOARD, 1 Speed TBE 156 N
				32020837	SCHEDA 2 Velocità CIRCUIT BOARD, 2 Speeds
			S12	31210130	IMPIANTO EL. TBE 156 S 380V. ELECTRICAL SYS. TBE 156 S 380V.
				31210148	IMPIANTO EL. TBE 156 S 220V. 50Hz ELECTRICAL SYS. TBE 156 S 220V. 50Hz
				31210131	IMPIANTO EL. TBE 156 DL 380V. ELECTRICAL SYS. TBE 156 DL 380V.
				31210139	IMPIANTO EL. TBE 156 DL 220V. 50Hz ELECTRICAL SYS. TBE 156 DL 220V. 50Hz
				31210140	IMPIANTO EL. TBE 156 DL 220V. 60Hz ELECTRICAL SYS. TBE 156 DL 220V. 60Hz
				31210129	IMPIANTO EL. TBE 156 N 380V. ELECTRICAL SYS. TBE 156 N 380V.
			S13	84990583	PORTAFUSIBILE 1P FUZE-HOLDER 1P
			S14	36020830	SCATOLA IMPIANTO EL.. ELECTRICAL SYSTEM BOX
			S15	32020833	SPORTELLLO CPL. CPL DOOR



TABELLA RICAMBI
 SPARE PARTS CODE
 TABLE PIECES DE RECHANGE
 ERSATZTEILLISTE
 TABLA REPUESTOS

TBE 156 S
 TBE 156 DL
 TBE 156 N

Posizione Position Position Position Posicion	Codice ricambio Spare parts code Code rechanger Ersatzteilcode Codigo repuesto	Descrizione Description Description Beschreibung Descripción	Posizione Position Position Position Posicion	Codice ricambio Spare parts code Code rechanger Ersatzteilcode Codigo repuesto	Descrizione Description Description Beschreibung Descripción
TAV. T					
T1	35019974	TUBO FLEX HOSE			
T2	35019974	TUBO FLEX HOSE			
T3	35015560	TUBO FLEX HOSE			
T4	35015559	TUBO FLEX HOSE			
T5	35019978	TUBO FLEX HOSE			
T6	35019979	TUBO FLEX HOSE			
T7	36019980	TUBO IDRAULICO HYDRAULIC HOSE			
T8					
T9	35019976	TUBO FLEX HOSE			
T10	35020158	TUBO FLEX HOSE			
T11	35019975	TUBO FLEX HOSE			
T12	35019975	TUBO FLEX HOSE			
T13	35019976	TUBO FLEX HOSE			

Note

A blank sheet of lined paper with horizontal dashed lines for writing. The lines are evenly spaced and extend across the width of the page. The word "Note" is printed at the top center in a bold, black font.



MONDOLFO FERRO S.p.a.

Viale dell'Industria, 20 - 61037 MONDOLFO (PU) Italy

Tel. 0721.93671 - Fax 0721.930238

export.dpt@mondolfoferro.it

commitalia@mondolfoferro.it

www.mondolfoferro.it

87820211C 0212

